

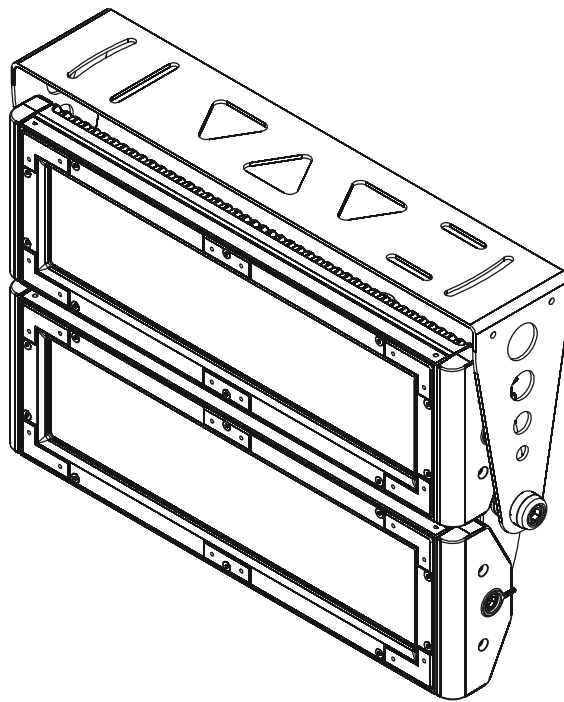

ArcPad Xtreme



USER MANUAL

Version 2.3

Table of contents

1. Safety instructions	3
2. Fixture exterior view	4
3. Installation	5
3.1 Mounting the fixture	5
3.2 Connection to the mains	6
3.3 Installation of the barn-doors, top/half top hats	7
3.4 Setting and control	7
3.5 DMX 512 connection	8
3.6 Master/slave connection	8
3.7 Stand-alone operation	8
4. ArcPad Xtreme (RGBCW) - DMX protocol.....	10
5. Control menu map.....	12
6. Fixture menu.....	14
6.1 Fixture Address	15
6.2 Fixture information.....	16
6.3 Personality	17
6.4 Manual mode.....	18
6.5 Test sequences.....	18
6.6 Stand-alone setting.....	18
6.7 Special functions.....	19
7. RDM	21
8. Error and information messages	22
9. Technical specifications	23
10. Cleaning and maintenance	26
11. Apendix.....	27
11.1 ArcPad Xtreme EPS	27

**FOR YOUR OWN SAFETY, PLEASE READ THIS USER MANUAL CAREFULLY
BEFORE POWERING OR INSTALLING YOUR ArcPad Xtreme !
Save it for future reference.**

This device has left our premises in absolutely perfect condition. In order to maintain this condition and to ensure a safe operation, it is absolutely necessary for the user to follow the safety instructions and warning notes written in this manual.

The manufacturer will not accept liability for any resulting damages caused by the non-observance of this manual or any unauthorized modification to the device.

Please consider that damages caused by manual modifications to the device are not subject to warranty.

1. Safety instructions

DANGEROUS VOLTAGE CONSTITUTING A RISK OF ELECTRIC SHOCK IS PRESENT WITHIN THIS UNIT!

Make sure that the available voltage is not higher than stated on the rear panel of the fixture.

This fixture should be operated only from the type of power source indicated on the marking label. If you are not sure of the type of power supplied, consult your authorized distributor or local power company.

Always disconnect the fixture from AC power before cleaning, removing or installing the fuses, or any part.

Do not overload wall outlets and extension cords as this can result in fire or electric shock.

Make sure that the power/data cord is never crimped or damaged by sharp edges. Check the fixture and the power/data cord from time to time.

Do not install the unit near naked flames.

During the operation the housing becomes hot (up to 85°C)

Refer servicing to qualified service personnel.

This fixture falls under protection class I. Therefore this fixture has to be connected to a mains socket outlet with a protective earthing connection.

Do not connect this fixture to a dimmer pack.

**LED light emission. Risk of eye injury.
Do not look straight at the fixture's LEDs during operation. The intense light beam may damage your eyes.**

Keep combustible materials at least 40 cm away from the fixture.

If the fixture has been exposed to drastic temperature fluctuation (e.g. after transportation), do not switch it on immediately. The arising condensation water might damage your device. Leave the device switched off until it has reached room temperature.

Do not shake the fixture. Avoid brute force when installing or operating the fixture.

The fixture was designed for indoor use and it is intended for professional application only. It is not for household use.

ArcPad Xtreme

When choosing the installation spot, please make sure that the fixture is not exposed to extreme heat or dust.

Avoid using the unit in locations subject to possible impacts.

The fixture body never must be covered with cloth or other materials.

Only operate the fixture after having checked that the housing is firmly closed and all screws are tightly fastened.

Make sure that the area below the installation place is blocked when rigging, derigging or servicing the fixture.

Do not block the front objective LEDs with any object when the fixture is under operation.

The fixture becomes very hot during operation. Allow the fixture to cool approximately 40 minutes prior to manipulate with it.

Operate the fixture only after having familiarized with its functions. Do not permit operation by persons not qualified for operating the fixture. Most damages are the result of unprofessional operation!

Do not attempt to dismantle or modify the unit.

Please consider that unauthorized modifications on the fixture are forbidden due to safety reasons!

Please use the original packaging if the fixture is to be transported.

If this device will be operated in any way different to the one described in this manual, the product may suffer damages and the guarantee becomes void. Furthermore, any other operation may lead to dangers like short-circuit, burns, electric shock etc.

2. Fixture exterior view

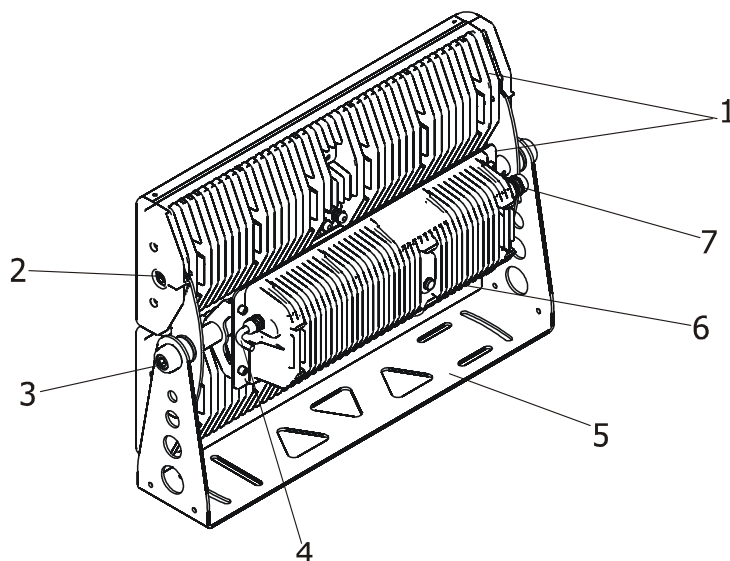

1. LED modules
2. Tilt-locks for LED modules
3. Tilt-lock for both LED modules
4. Power/data cable

5. Mounting bracket
6. Control unit
7. LED modules supply

3. Installation

3.1 Mounting the fixture

Ensure that the structure (truss, wall) to which you are attaching the fixture is secure.

The ArcPad Xtreme can be arranged in any position orientation. The ArcPad Xtreme allows to adjust its LED modules to the desired position either both modules together (by means of the Allen key 14) or each module separately (by means of the self-locking screws).

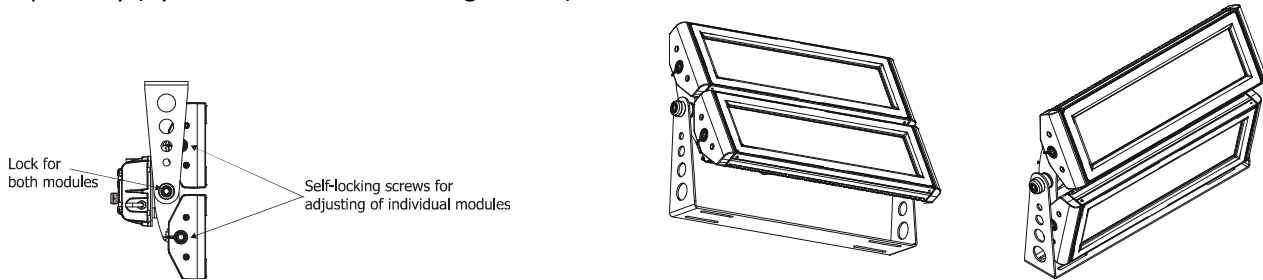

Danger of injury! Two workers have to handle with the fixture including adjusting the LED modules to the desired position. The LED modules are very heavy.

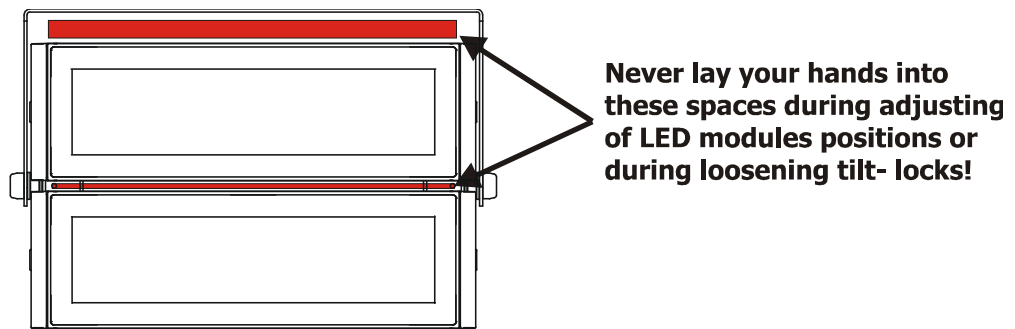

Five slots in the mounting bracket serve for mounting the fixture on non-flammable flat surface.

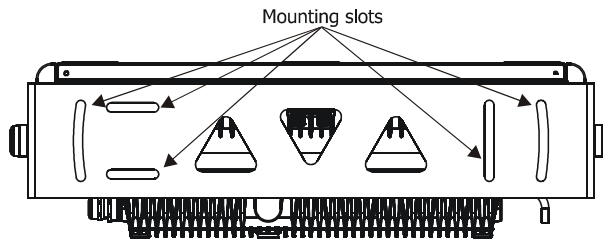

Caution: Overhead installation requires experience. Fixtures may cause severe injuries when crashing down! If you have doubts concerning the safety of a possible installation, do not install the device and consult installation with an expert.

3.2 Connection to the mains

Fixtures must be installed by a qualified electrician in accordance with all national and local electrical and construction codes and regulation

The ArcPad Xtreme is equipped with a 5-cored power/data cable. The 3 cores serve for the power supply and next 2 shielded cores are intended for DMX connection.

The power cores are coloured according to the following table.

Core	Connection	Plug Terminal Marking
Black	Live	L
Blue	Neutral	N
Yellow/Green	Earth	

This device falls under class one and must be grounded!

The data cores (DMX) are coloured according to the table:

Core	Connection
Brown	Data +
White	Data -
Shielding	Data ground

The power/data cable is connected to a junction box as shown on the picture below.

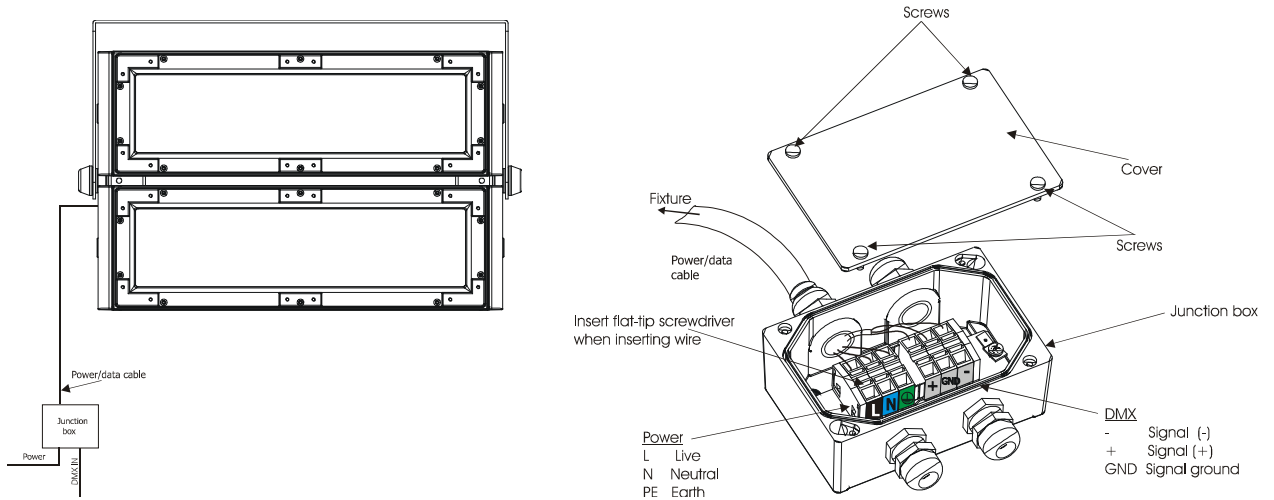

3.3 Installation of the barn-doors, top/half top hats

You can install barn-doors or top hats to better define illuminated surface.

Before installing the equipment disconnect the fixture from the mains.

1. Fit the barn-doors module (1) or top/half top hat (2) on the LED module (4) and fasten it by means of the 12 screws (3) as shown on the picture below.
2. Repeat the same steps for the second LED module of the fixture.

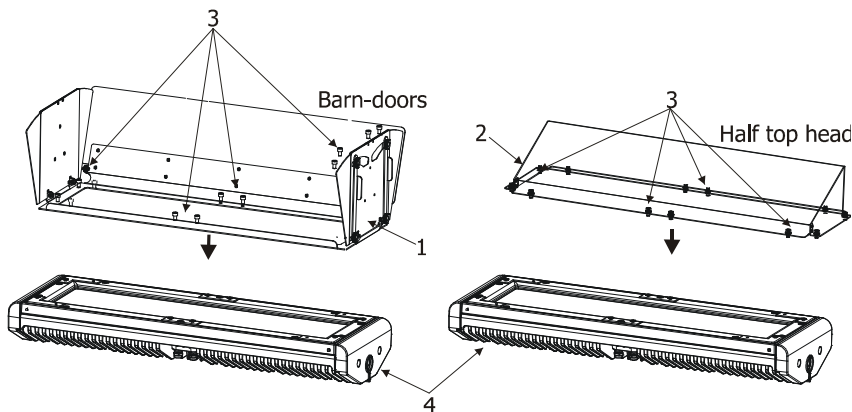

Never close the barn-doors during fixture operation!

3.4 Setting and control

For setting DMX address, selecting DMX mode and for another settings you need either Robe Universal Interface or the RDM Communicator. Please see the Robe Universal Interface or RDM Communicator user manuals to get more information about this products. The way, how to connect these interfaces to the DMX data link is figured below.

NOTE: never connect the RDM communicator and the The Robe Universal Interface to the fixture at the same time.

1. Robe Universal Interface

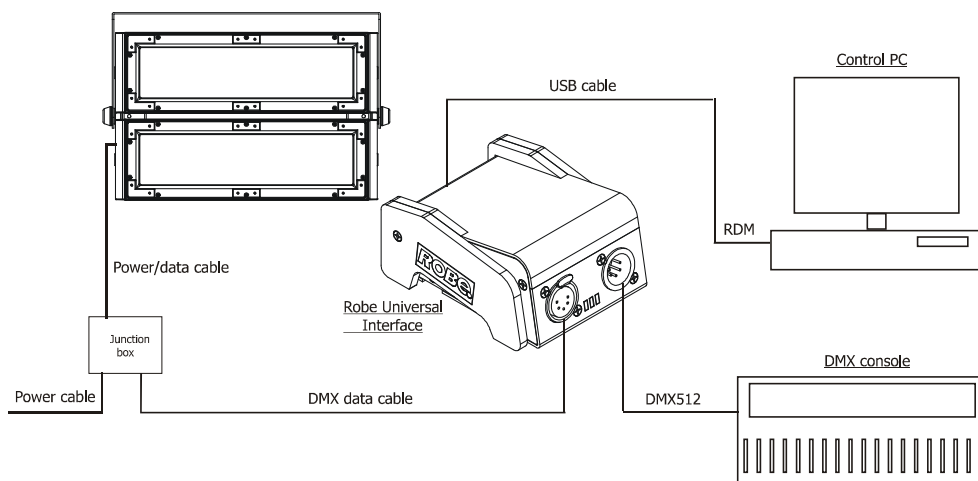

2. RDM Communicator

Note: DMX controller has to be disconnected from the fixture when the RDM communicator is operated.

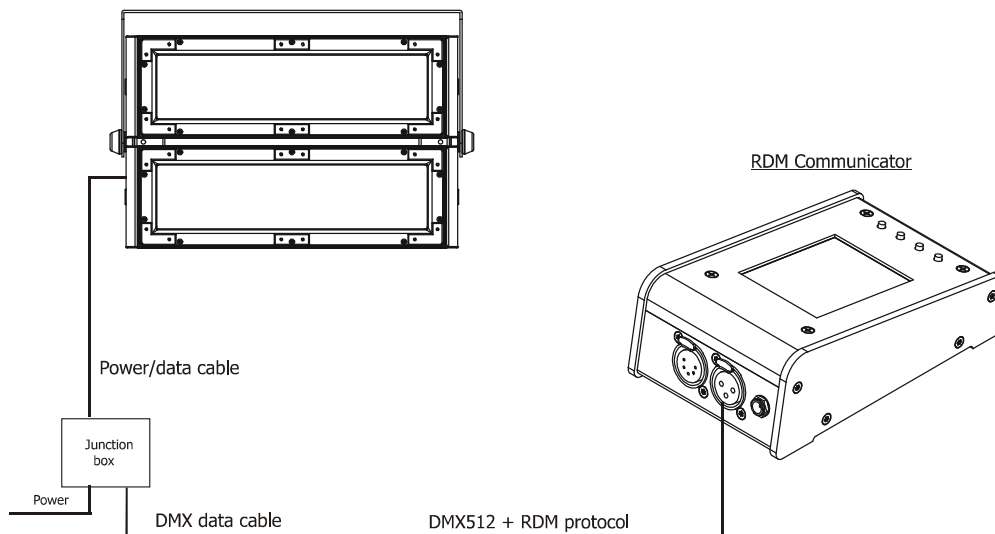

3.5 DMX 512 connection

To build a DMX chain

1. Connect the DMX output of the controller directly with the DMX input of the first fixture in the DMX chain.
2. Connect the DMX output of the first fixture in the DMX chain with the DMX input of the next fixture.
3. Always connect the DMX output with the input of the next fixture until all fixtures are connected.

Do not overload the link. Max. 32 fixtures may be connected on a DMX link.

Caution: Terminate the output of the last fixture with a 120 Ohm resistor wired between data (+) and data (-) in order to ensure the proper transmission on the data link.

3.6 Master/slave connection

To build a master/slave-chain:

Connect the DMX output of the master fixture in the data chain with the DMX input of the first slave. Always connect output with the input of the next slave until all slaves are connected (up to 32 fixtures).

Caution: It is necessary to terminate the input of the master fixture and the output of the last slave with a 120 Ohm resistor in order to ensure the proper transmission on the data link.

3.7 Stand-alone operation

The fixtures on a data link are not connected to the controller but can execute pre-set programs which can be different for every fixture. To set the program to be played, see the "Stand-alone setting" (menu "St.AL."). "Stand-alone operation" can be applied to the single fixture or to multiple fixtures operating synchronously. Synchronous operation of multiple fixtures requires that they must be connected on a data link and one of them is set as a master (master mode) and the rest as the slaves (slave mode).

To set the fixture as the master or slave, see the " Fixture Address " (menu "A001").

Only one fixture can be set as the master.

The master fixture starts simultaneous program start in the other slave fixtures. All fixtures have a definite, synchronized starting point when playing back their programs. The number of running program is the same in all slaves and depends on the master's choice (menu "St.AL."). Every fixture runs its program repeatedly, starting the program step No.1 when requested by the master.

Example:

If the slave fixture has a shorter program length, it will continuously repeat its program until the master fixture finishes its own program and restarts its program running (slave 1- prog.step 3 will not be finished).

If the slave fixture has a longer program length, it will restart at prog. step 1 before it completes all its prog.steps (slave 2 - prog.step 5 will not be played)- see the picture bellow.

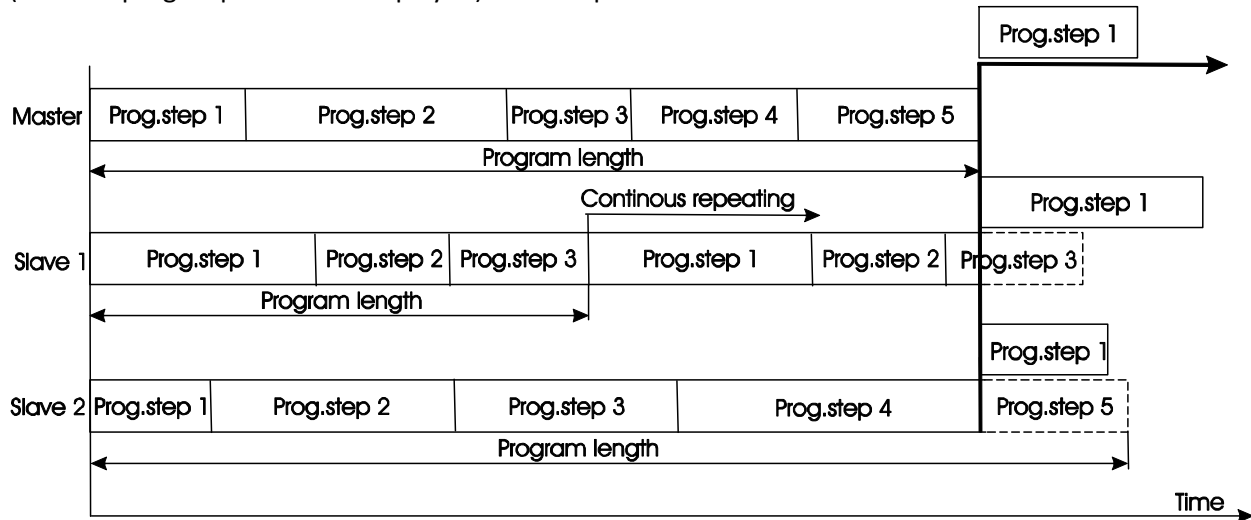

Note: Disconnect the fixtures from the DMX controller before master/slave operating, otherwise data collisions can occur and the fixtures will not work properly!

4. ArcPad Xtreme (RGBCW) - DMX protocol

Version 1.0

Mode/Channel						Value	Function	Type of control
1	2*	3	4	5	6			
-	1	1	1	-	-	0 - 255	Red LEDs - both LED modules Red LEDs saturation control (0-100%)	proportional
-	2	2	2	-	-	0 - 255	Green LEDs - both LED modules Green LEDs saturation control (0-100%)	proportional
-	3	3	3	-	-	0 - 255	Blue LEDs - both LED modules Blue LEDs saturation control (0-100%)	proportional
-	-	4	4	-	-	0 - 255	White LEDs - both LED modules White LEDs saturation control (0-100%)	proportional
-	-	-	-	1	1	0 - 255	Red LEDs – LED module 1 Red LEDs saturation control (0-100%)	proportional
-	-	-	-	2	2	0 - 255	Green LEDs - LED module 1 Green LEDs saturation control (0-100%)	proportional
-	-	-	-	3	3	0 - 255	Blue LEDs - LED module 1 Blue LEDs saturation control (0-100%)	proportional
-	-	-	-	4	4	0 - 255	White LEDs - LED module 1 White LEDs saturation control (0-100%)	proportional
-	-	-	-	5	5	0 - 255	Red LEDs - LED module 2 Red LEDs saturation control (0-100%)	proportional
-	-	-	-	6	6	0 - 255	Green LEDs - LED module 2 Green LEDs saturation control (0-100%)	proportional
-	-	-	-	7	7	0 - 255	Blue LEDs - LED module 2 Blue LEDs saturation control (0-100%)	proportional
-	-	-	-	8	8	0 - 255	White LEDs - LED module 2 White LEDs saturation control (0-100%)	proportional
1	-	-	5	-	9	0 1-15 16 17-55 56 57 - 95 96 97 – 134 135 136 - 174 175 176 -214 215	Colour macros (255 values) – both LED modules No function (for DMX mode 4 and 6) White (for DMX mode 1) White tones (cool→warm) Blue (Blue=full, Red+Green+White=0) Red=0, Green→up,Blue =full, White=0 Light Blue (Red=0, Green=full, Blue =full, White=0) Red=0, Green=full, Blue→down, White=0 Green (Red=0, Green=full, Blue =0, White=0) Red→up, Green=full, Blue=0, White=0 Yellow (Red=full, Green=full, Blue=0, White=0) Red=full, Green→down, Blue=0, White=0 Red (Red=full, Green=0, Blue=0, White=0) Red=full, Green=0, Blue→up, White=0 Magenta (Red=full, Green=0, Blue=full, White=0)	step proportional step proportional step proportional step proportional step proportional step

Mode/Channel						Value	Function	Type of control
1	2*	3	4	5	6			
1	-	-	5	-	9	216 - 254 255	<u>Colour macros – both LED modules</u> Red→down, Green=0, Blue=full, White=0 Blue (Red=0, Green=0, Blue=full, White=0)	proportional step
-	-	-	6	-	10	0-31 32-63 64-95 96-127 128-143 144-159 160-191 192-223 224-255	<u>Shutter/ Strobe – both LED modules</u> Shutter closed Shutter open Strobe-effect from slow to fast Shutter open Opening pulses in sequences slow--> fast Closing pulses in sequences fast --> slow Shutter open Random strobe-effects from slow to fast Shutter open	step step proportional step proportional proportional step proportional step
2	-	-	7	-	11	0 - 255	<u>Dimmer – both LED modules</u> Dimmer intensity from 0% to 100%	proportional
-	-	-	8	-	12	0 - 255	<u>Dimmer fine – both LED modules</u> Fine dimmer intensity from low to high	proportional

*White LEDs lit proportionally when Red+Green+Blue LEDs are saturated together.

5. Control menu map

Default settings=**Bold print**

Menu Level 1	Menu Level 2	Menu Level 3	Menu Level 4	Menu Level 5	Menu Level 6
A001	dM.Ad.	001-512			
	MA.SL.	d.AbL			
		MASt.			
		SLA			
InFo	Poti.	totL	totL		
		rSEt	rSEt		
	DM.In.	rEd1	0-255		
		:			
		F.dim	0-255		
	tEMP.	Cur.t.	boAr.		
			LEdS		
		Hi.tE.	boAr.		
			LEdS		
		rSEt	boAr.		
			LEdS		
	VErS.	IC1			
		IC2			
PErS	dM.Pr.	Mod.1			
		Mod.2			
		Mod.3			
		Mod.4			
		Mod.5			
		Mod.6			
	dISP.	d.On	On, Off		
		d.Int.	20...100		
		turn	On, Off		

ArcPad Xtreme

Menu Level 1	Menu Level 2	Menu Level 3	Menu Level 4	Menu Level 5	Menu Level 6
	tEM.U.	°C, °F			
	bALA	On, Off			
	C.bAL.	rEd	0..200..255		
		GrEn	0.....255		
		bLuE	0..237..255		
		Stor			
	LOAd	FuLL			
		EcO			
	In.Po.	rEd1	0-255		
		:			
		F.dim	0-255		
		Stor.			
	dFSE				
MAAn.M.	PrE.C.	rEd1	rE1.1..rE1.3		
		:			
		dimr	dim0...dim.7		
	Man.C.	rEd1	0-255		
		:			
		F.dim	0-255		
TESt					
St.AL.	Auto	Off			
		tESt			
		PrG.1			
		:			
		PrG.3			
	PLAY	tESt			
		PrG.1			
		:			

Menu Level 1	Menu Level 2	Menu Level 3	Menu Level 4	Menu Level 5	Menu Level 6
		PrG.3			
	Edit	PrG.1	St.01	rEd1	0-255
		:	:	:	:
		PrG.3	St.68	S.tim.	0-25.5 sec
				CoPY	
SPEC.	rdML				
	rdMH				
	Adj.	DMH	rEd1		
			:		
			F.dimr		
		CaL.U.	rEd1		
			:		
			Wh4		
			Stor.		
	uPd.				

6. Fixture menu

RDM communicator:

Connect the RDM communicator to the fixture and from the menu "Control" select the "Remote LED display" item. The fixture's control display with the four control buttons will appear on the screen of the RDM communicator.

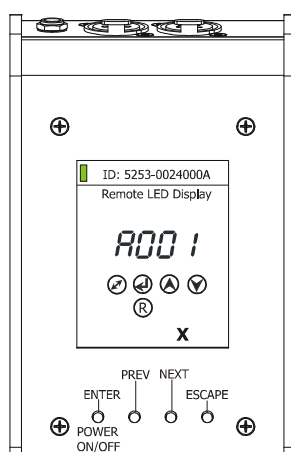

The control buttons have the following functions:

- ↖ - **ESCAPE** button-leaves menu without saving changes.
- ↵ - **ENTER** button- enters menu, confirms adjusted values and leaves menu.
- ▲ - **UP** and ▼ - **DOWN** buttons - move between menu items on the same level, sets values.
- ▲

Robe Universal Interface:

Run the RDM-network and click with the right button of the mouse on the fixture and select the **Remote LED display** option from the menu list as shown below.

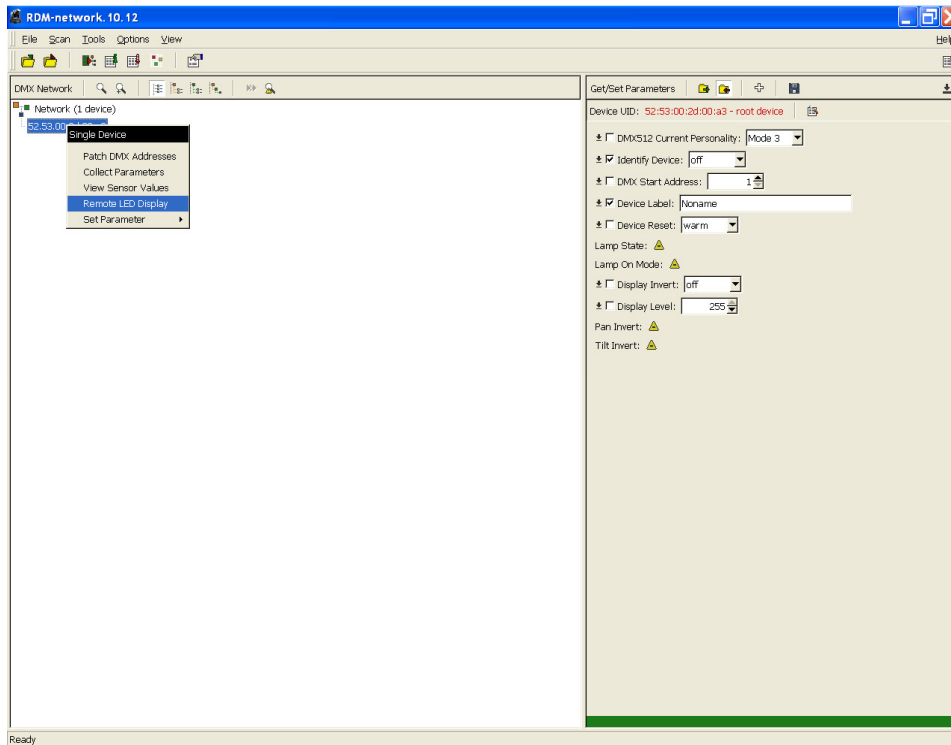

The Remote LED Display window will appear. Now you can fully control the fixture using the **UP**, **Down**, **Enter**, **Escape** and **Reset** buttons.

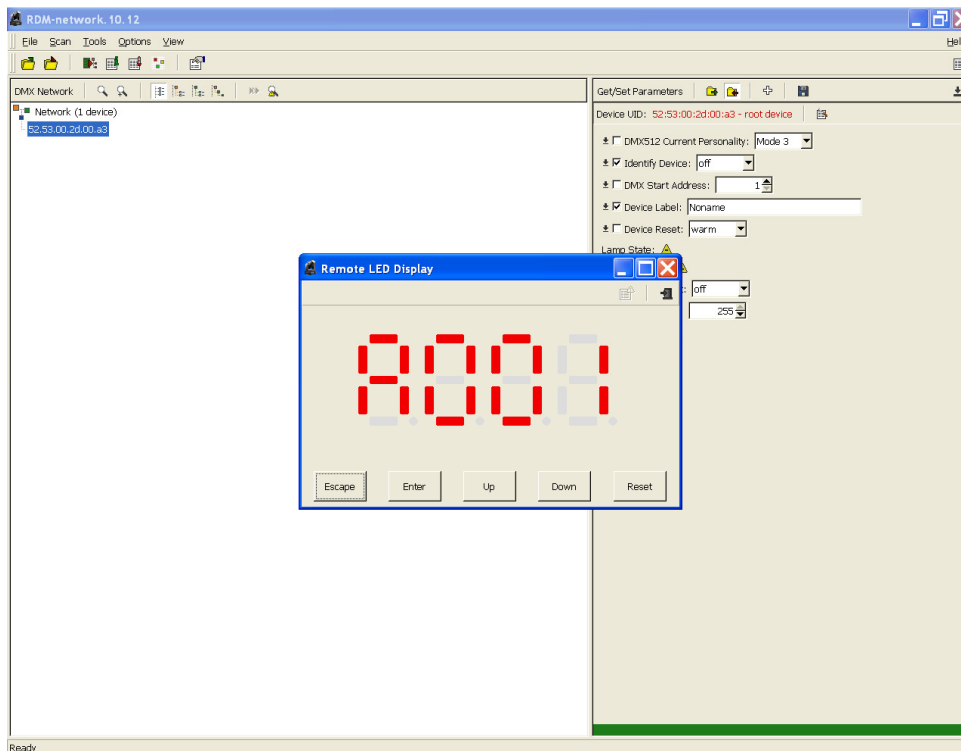

6.1 Fixture Address



Use this menu to set the DMX address of the fixture or set the fixture as a Master (Slave).

dM.Ad. --- **DMX addressing.** Select this submenu to set a DMX start address.

To set a DMX address.

1. Use the UP/DOWN buttons to find “ **A001** ” menu.
2. Press the ENTER button.
3. Use the UP/DOWN buttons to select desired start address.
4. Press the ENTER button to confirm the choice.

MA.SL. --- **Master/slave addressing.** Select this submenu to set the fixture as a master or slave. Option "**d.ABL**" deactivates master/slave setting.

To set a fixture as a master or slave.

1. Use the UP/DOWN buttons to find “A001” menu.
2. Press the ENTER button.
3. Use the UP/DOWN buttons to select “ **MA.SL.** ” item.
4. Press the ENTER button.
5. Use the UP/DOWN buttons to select either master (MASt) or slave (SLA)
6. Press the ENTER button to confirm the choice.

Note: After switching on, the ArcPadXtreme will automatically detect whether DMX 512 data is received or not. If there is no data received at the DMX input, the display will start to flash “A001” with actually set address.

6.2 Fixture information



Use this menu to read useful information about the fixture status.

To display desired information.

1. Use the UP/DOWN buttons to find the “ InFo ” menu.
2. Press the ENTER button.
3. Use the UP/DOWN buttons to select the required menu item.
4. Press the ENTER button to confirm the choice.

Po.ti. --- **Power On Time.** Use the menu item to read the number of operation hours for each LEDs operating mode.

totL - the function shows the total number of the operation hours since the ArcPad Xtreme has been fabricated.

rESet - the function shows the number of the operation hours that the ArcPad Xtreme has been powered on since the counter was last reset. In order to reset this counter to 0 you have to press and hold the UP and DOWN buttons and at the same time press the ENTER button.

DM.In.---**DMX values.** Select this function to read DMX values of each channel received by the fixture.

tEMP --- **Fixture Temperatures.** Select this menu to read the temperatures of the fixture:

Cur.t. --- the current temperature of the fixture inside.

Hi.tE. - the menu item shows the max. temperatures of the fixture inside since the ArcPad Xtreme has been fabricated.

rSEt --- the menu item shows the maximum temperatures of the fixture inside since the counter was last reset. In order to reset this counter to 0 you have to press and hold the UP and DOWN buttons and at the same time press the ENTER button.

Note: The ambient temperature should not exceed 40°C.

Measuring points:

LEdS.--- the temperature of the LEDs module.

boAr. --- the temperature on the PCB in the fixture head.

The temperatures can be displayed in either °C or °F units - see option "tEM.U" in the menu "Pers".

VErS. --- **Software Versions.** Select this function to read the software versions of the fixture processors.

IC1 --- the processor controls LEDs module

IC2 --- EEprom

6.3 Personality



Use this menu to modify the ArcPad Xtreme operating behaviour.

DM.Pr. --- **DMX preset.** Select this menu item to set a desired DMX mode. Please refer to the chapter "DMX protocol" for detail description of each DMX mode.

DiSP. --- **Display adjusting.** This function allows you to change the display settings.

d.On --- this function allows you to keep the display on or to turn off automatically 2 minutes after last pressing any button on the control panel.

d.Int. --- select this function to adjust the display intensity (20-min.,100-max.).

turn --- select this function to turn the display by 180°.

tEM.U. --- **Temperature Unit.** Use this menu in order to display the fixture temperatures in desired units: °C or °F.

bALA --- **Balance** Use this menu item to enable (On) or disable (Off) the white balance which is set in the "White colour balance" menu below. If this function is set off, the will use maximum values (255) of saturation for red, green and blue colour. This function has to be set on before adjusting a white balance.

C.bAL. --- **White Colour Balance.** The menu gives access to the setting of the white balance.

To set the white colour balance.

1. Use a DMX controller or the " Man.C." menu to set all LEDs on max. saturation.
2. Use the UP/DOWN buttons to find the " Pers." menu.
3. Press the ENTER button.
4. Use the UP/DOWN buttons to select the "C.bAL" menu.
5. Press the ENTER button and the "rEd" item will appear on the display.
6. Press the ENTER button and use the UP/DOWN buttons to set new max. value for the red LEDs.
7. Press the ENTER button to confirm the choice.
8. Use the UP/DOWN buttons to select next colour, the "GrEn".
9. Repeat steps 6-7 for this channel.
10. Use the UP/DOWN buttons to select the last colour, the „bLuE" and repeat steps 6-7 for this colour.

LoAd --- **Load of LEDs.** The menu allows to choose 2 operating modes for fixture.

FuLL --- Maximum light output.

EcO. --- The light output is decreased by 25%.

In.Po. --- **Init effect positions.** Use this function to set all effects to the desired positions to which they will move after switching the fixture on (if DMX is not being received).

Note. If DMX mode 1 is selected, only values set at items "MACr" (macro) and dinr (dimmer) will be accepted.

dF.SE. --- **Default Settings .**The menu item sets all fixture parameters to the default (factory) values.

6.4 Manual mode



Use this menu for control the fixture without connected DMX console.

PrE.C. --- Preset effects control. Select this menu to call up preset positions of the channel effects.

Man.C. --- Manual effect control. Select this menu to control all channels via buttons of the control board.

To control fixture channels.

1. Use the UP/DOWN buttons to find " Man.C" menu.
2. Press the ENTER button.
3. Use the UP/DOWN buttons to select desired effect (channel).

List of control channels:

"rEd1" - "rEd2" - red LEDs saturations, LED modules 1 and 2

"GrE1" - "GrE2" - green LEDs saturations, LED modules 1 and 2

"bLu1" - "bLu2" - blue LEDs saturations, LED modules 1 and 2

"Whi1" - "Whi2" white LEDs saturations, LED modules 1 and 2

"MACr" - colour macros

"Stro." - a strobe, shutter

"dimr" - a dimmer

4. Press the ENTER button and use the UP/DOWN buttons to set value , press the ENTER button to confirm it.

6.5 Test sequences



Use this menu to run demo-test sequences without an external controller, which will show you some possibilities of using the ArcPad Xtreme.

6.6 Stand-alone setting



The fixtures on a data link are not connected to the controller but can execute pre-set programs which can be different for every fixture. "Stand-alone operation" can be applied to the single fixture or to multiple fixtures operating synchronously.

Synchronous operation of multiple fixtures requires that they must be connected on a data link and one of them is set as a master ("MASt") and the rest as the slaves ("SLA"). Up to 32 fixtures can be connected in a master/slave chain. Only one fixture can be set as the master.

Note: Disconnect the fixtures from the DMX controller before master/slave operating, otherwise data collisions can occur and the fixtures will not work properly. See the chapters "Stand-alone operation" and " Master/slave connection".

Auto. --- **Automatic playback.** This function allows you to select the program which will be played after switching the fixture on. Selected program will be played continuously in a loop.

1. Use the UP/DOWN buttons to find " St.AL." menu.
2. Press the ENTER button.
3. Use the UP/DOWN buttons to select " Auto" item.
4. Press the ENTER button.
5. Use the UP/DOWN buttons to select desired program.
6. Press the ENTER button to confirm the choice.

PLAY --- **Playing program.** By enter to this menu a complete overview of all programs is offered, from which the program to be run can be selected.

1. Use the UP/DOWN buttons to find “ **St.AL.**” menu.
2. Press the ENTER button.
3. Use the UP/DOWN buttons to select desired program.
4. Press the ENTER button. The selected program runs in a loop.

Edit --- Editing a program. The fixture offers 3 freely editable programs (EPG.1-EPG.3) each up to 68 steps. Every program step includes a fade time-the time taken by the step’s channel status to reach the desired level and a step time-the total time occupied by the step in the program.

E.g. If “F.tim.”=5 second and “S.tim.”=20 second, effects will go to the desired position during 5 seconds and after that they will stay in this position for 15 seconds before going to the next prog. step

1. Use the UP/DOWN buttons to find “ **St.AL.**” menu and press the ENTER button.
2. Use the UP/DOWN buttons to select “Edit” menu and press the ENTER button.
3. Use the UP/DOWN buttons to select a program you want to edit (PrG.1-PrG.3 and press ENTER button.
4. Use the UP/DOWN buttons to select a desired program step ("St.01" - "St.68") and press ENTER button.
5. Use the UP/DOWN buttons to select a channel you want to edit and press the ENTER button.

List of editable items:

“P.End” - a total number of the program steps (value 1-68). This value should be set before start Programming (e.g. if you want to create program with 10 steps, set P.End=10).

“rEd1” - “rEd2” – a red LEDs saturation(0-255), module 1-2

“GrE1” - “GrE2” – a green LEDs saturation (0-255)), module 1-2

“bLu1” - “bLu2” – a blue LEDs saturation (0-255)), module 1-2

“Whi1” - “Whi2” – a white LEDs saturation (0-255)), module 1-2

“MACr”- colour macros (0-255), both modules

“Stro.” - a strobe, shutter (0-255), both modules

“dimr” - a dimmer (0-255), both modules

“F.tim.”- a fade time, (0-25.5) seconds

“S.tim.”- step time, value (0-25.5) seconds

“COPY” – this item duplicates the current prog. step to the next prog. step. The item “P.End” is increased automatically.

6. Use the UP/DOWN buttons to set a DMX value of the channel and then press the ENTER button.
7. Use the UP/DOWN buttons to select next channel and press the ENTER button.
8. After having set all channels in the current program step, press the MODE button to go by one menu level back and select another program step.

6.7 Special functions



rdML --- **Code.** This menu item shows the first part of the RDM identification code.

rdMH --- **Code.** This menu item shows the second part of the RDM identification code.

Adj --- **Effect Adjustment.** The menu allows calibration of each LEDs array.

dMH --- **DMX Values.** The menu item enables to control all LEDs before calibrating each LEDs array.

CAL.U --- **Calibrating unit.** The menu serves for fine current calibration of LEDs during fixture burn-in at a factory. Each LED array can be calibrated separately. Users should not change the setting.

uPd.M. --- **Updating mode.** The menu item allows you to update software in the fixture via either serial or USB port of PC.

The following are required in order to update software:

- PC running Windows 95/98/2000/XP or Linux
- DMX Software Uploader

- Flash cable RS232/DMX No.13050624 (if you want to use a serial port of PC)
- Robe Universal Interface (if you want to use an USB port of PC)

Note1: Software update should execute a qualified person. If you lack qualification, do not attempt the update yourself and ask for help your ROBE distributor.

Note 2: DMX address, programs 1-3 and all items in the menu "PERs" will be set to their default values.

To update software in the fixture:

I. Installation of the DMX Software Uploader.

1. DMX Software Uploader program is available from the Anolis web site at WWW.anolis.cz.
2. Make a new directory (e.g. Anolis_Uploader) on your hard disk and download the software into it.
3. Unpack the program from the archive.

II. Fixture software updating.

If you use the RDM Communicator:

1. Disconnect the fixture from other fixtures in a DMX link.
2. Connect the RDM communicator to the fixture and switch this fixture to the update mode :
 - 1 Use the UP/DOWN buttons to find "SPEC." menu.
 - 2 Press the ENTER button.
 - 3 Use the UP/DOWN buttons to select " uPd." item.

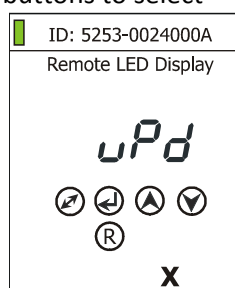

- 4 Press the ENTER button
- 5 Use the UP/DOWN buttons to select " yES" option
- 6 Press the ENTER button

Note: If you do not want to continue in software update, you have to switch off and on the fixture to escape from this menu.

3. Disconnect the RDM communicator from the fixture.
4. Connect serial port of your PC with a DMX input of the fixture if you using the flash cable RS232/DMX.

If you use the Robe Universal Interface:

1. Disconnect the fixture from other fixtures in a DMX link.
2. Connect the Robe Universal Interface to the fixture and switch this fixture to the update mode :
 1. Run the RDM-Network and select menu item "Remote LED Display"
 2. Use the UP/DOWN buttons to find "SPEC." menu.
 3. Press the ENTER button.
 4. Use the UP/DOWN buttons to select " uPd." item.



5. Press the ENTER button
6. Use the UP/DOWN buttons to select " yES" option
7. Press the ENTER button

Note: If you do not want to continue in software update, you have to switch off and on the fixture to escape from this menu.

8. After switching the fixture to the update mode cancel the RDM-Network program.

Run the Software Uploader program. Select desired COM and then click on the Connect button.
 Note: we recommend to cancel all running programs before starting the Software Uploader.

Select COM if the serial port is used.

Select DreamBox1 if the USB port is used.

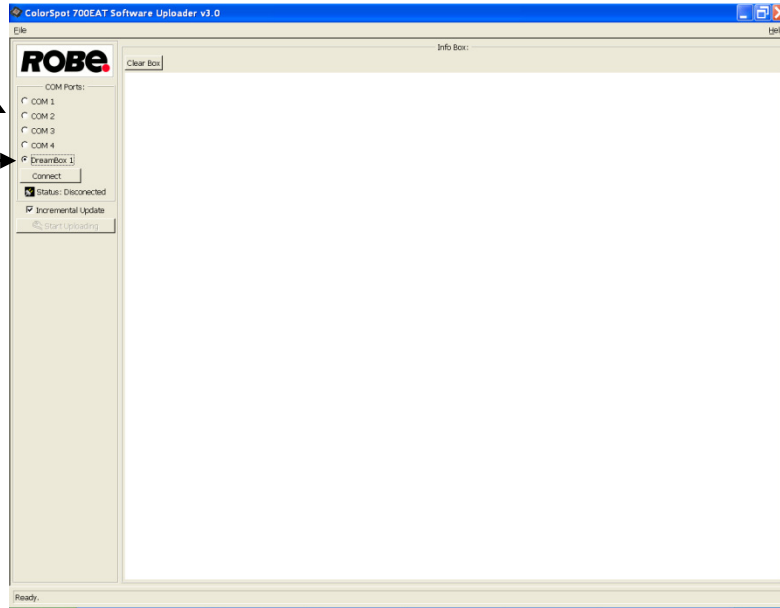

If the connection is OK, click on the Start Uploading button to start uploading. It will take several minutes to perform software update. If the option "Incremental Update" is not checked, all processors will be updated (including processors with the same software version). If you wish to update only the latest versions of processors, check the Incremental Update box. Avoid interrupting the process. Update status is being displayed in the Info Box window. When the update is finished, the line with the text "The fixture is successfully updated" will appear in this window and the fixture will reset with the new software.

7. RDM

This fixture is ready for RDM operation. RDM (Remote Device Management) is a bi-directional communications protocol for use in DMX512 control systems, it is the new open standard for DMX512 device configuration and status monitoring.

The RDM protocol allows data packets to be inserted into a DMX512 data stream without adversely affecting existing non-RDM equipment. By using a special „Start Code,“ and by complying with the timing specifications for DMX512, the RDM protocol allows a console or dedicated RDM controller to send commands to and receive messages from specific moving lights.

RDM allows explicit commands to be sent to a device and responses to be received from it.

The list of commands for ArcPad Xtreme is the following.

Parameter ID	Discovery command	SET command	GET command
DISC_UNIQUE_BRANCH	*		
DISC_MUTE	*		
DISC_UN_MUTE	*		
DEVICE_INFO			*
SUPPORTED_PARAMETERS			*

Parameter ID	Discovery command	SET command	GET command
SOFTWARE_VERSION_LABEL			*
DMX_START_ADDRESS		*	*
IDENTIFY_DEVICE		*	*
DEVICE_MODEL_DESCRIPTION			*
MANUFACTURER_LABEL			*
DEVICE_LABEL		*	*
SENSOR_DEFINITION			*
SENSOR_VALUE			*
DISPLAY_LEVEL		*	*
DEVICE_RESET		*	
DMX_PERSONALITY		*	*
DMX_PERSONALITY_DESCRIPTION			*
STATUS_MESSAGES			*
STATUS_ID_DESCRIPTION			*
DEVICE_HOURS			*

8. Error and information messages

t.M.Er.(Temperature measuring error)

The message informs you that the LED module temperature sensor is defective.

MA.Er. (Master error)

The fixture is set as a master and DMX console is connected to the fixture.

9. Technical specifications

Power supply

- Electronic auto-ranging
- Input voltage: 100 - 250V AC, 50-60 Hz
- Power consumption

Power mode	Max. power consumption (All LED channels at full)	Typical power consumption (2 LED Channels at full)	Ambient Temperature
Full mode	580W (590VA)	310W	25°C
Eco mode	300W (320VA)	160W	

- Fuse: F12A/250V

Optic & Effects

- Light source: 188 ProLight Opto 3 Watt Proeon LEDs (56 red, 44 green, 44 blue, 44 white)
- Available optical system: 9°, 22°, 45° or 10°x20°
- RGBW colour mixing
- Built-in colour macros
- Adjustable strobe sequences
- White colour balance adjusting
- Lumen maintenance:

Channels @ full intensity	Power mode	L ₇₀
One LED channel	Full mode	95,000
	Eco mode	108,000
Two LED channels	Full mode	90,000
	Eco mode	102,000
Three LED channels	Full mode	84,000
	Eco mode	95,000
All LED channels	Full mode	77,000
	Eco mode	88,000

L₇₀ = 70% maintenance of initial lumen output in hours

Electronics

- Control: USITT DMX 512 (RDM support)
- Control options: DMX, RDM
- Operations modes: DMX, Master/Slave
- DMX protocol modes: 6 (2,3,4,8,12) control channels
- Manual control of all effects via RDM communicator
- 3 user editable programs each up to 68 steps

Strobe

- Strobe effect with variable speed (max. 20 flashes per second)
- Pre-programmed random strobe pulse-effects

Dimmer

- Smooth 16-bit dimming from 0 - 100 %

Connection

- Power/data cable: Li9YCHY Cable 3xAWG16+1x (2xAWG24 Shielded and Jacketed)
- junction box

ArcPad Xtreme

Rigging

- Via mounting bracket

Temperatures

- Maximum ambient temperature: 40° C
- Maximum housing temperature: 85° C

Dimensions (mm)

ArcPad Xtreme

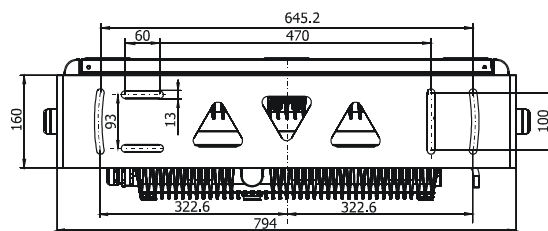
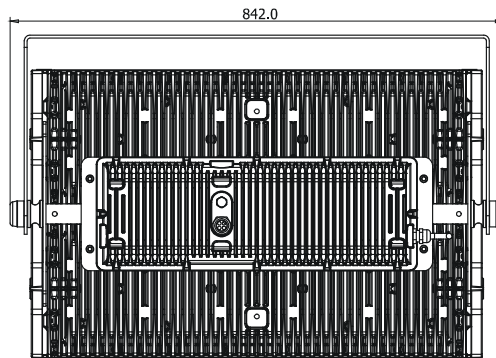
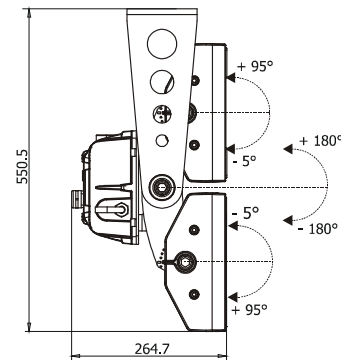
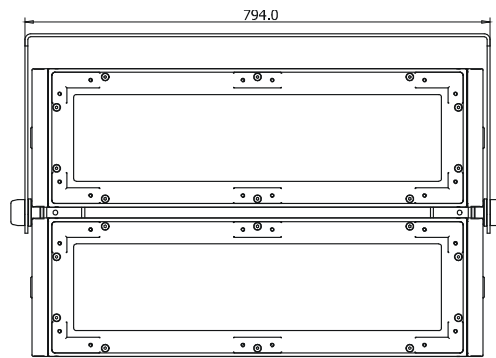

Junction box

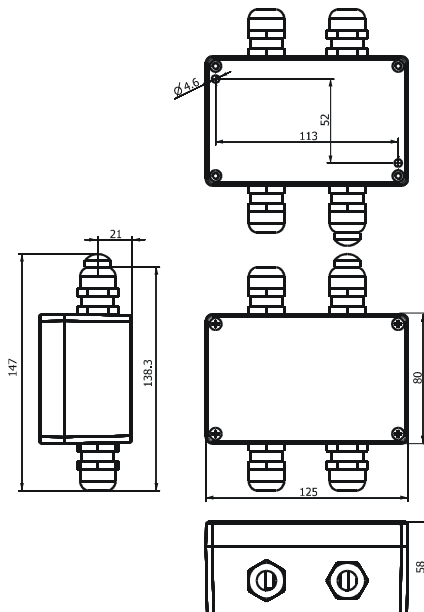

Weight

- 57 kg

Protection factor

- IP 67, IP 66 junction box

Included items

- 1 x ArcPad Xtreme
- 1 x Junction box (No.99012672)
- 1 x Allen key 14
- 1 x User manual

Optional accessories

- Barn-doors in silver colour (No. 10980081)
- Top hat in silver colour (No. 10980087)
- Half top hat in silver colour (No. 10980088)

Note: By reason of the fast-moving development of LED technology, newer products may have better light parameters than previous products.

10. Cleaning and maintenance

DANGER !
Disconnect from the mains before starting any cleaning or maintenance work

Rinse off loose dirt with a garden hose or low pressure water spray. Wash the housing with a soft brush or sponge and a mild, non-abrasive washing detergent. Rinse it.

There are no serviceable parts inside the device.

Maintenance and service operations are only to be carried out by a qualified person.

Should you need any spare parts, please use genuine parts.

If the power supply cable of this device will be damaged (cable firmly connected with the device), it has to be replaced by authorized distributors only in order to avoid hazards.

11. Appendix

11.1 ArcPad Xtreme EPS

Besides the ArcPad Xtreme exists variant with separated LED modules and control unit, which is named the ArcPad Xtreme EPS. Its differences compared to the ArcPad Xtreme integral are described below. Control ans setting is the same as at the compact version.

Fixture exterior view

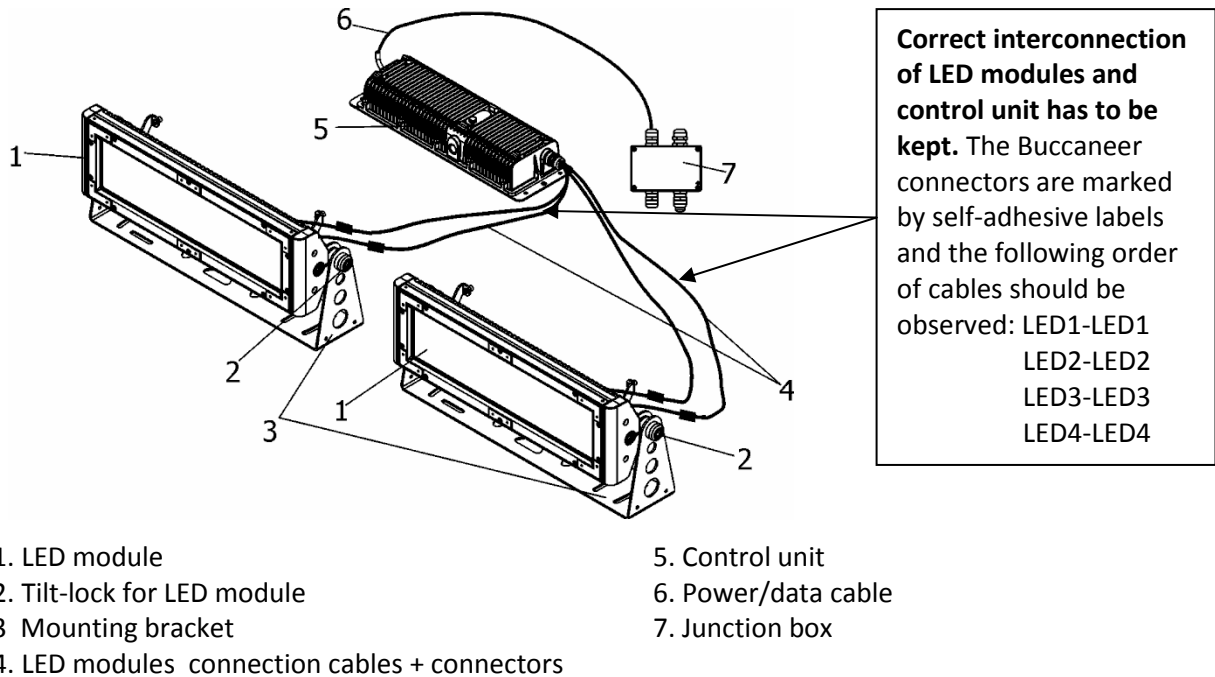

Connection between LED modules and control unit

Four pairs of the Belden 7930A cables serve for interconnection of the LED modules and the control unit. The Buccaneer connectors are marked by self-adhesive labels (LED1, LED2, LED3, LED4) next to the connectors and the following order of cable connections has to be kept to ensure correct operation of the fixture:

LED1-LED1
LED2-LED2
LED3-LED3
LED4-LED4

Max. length between LED module and control unit must not exceed 20m.

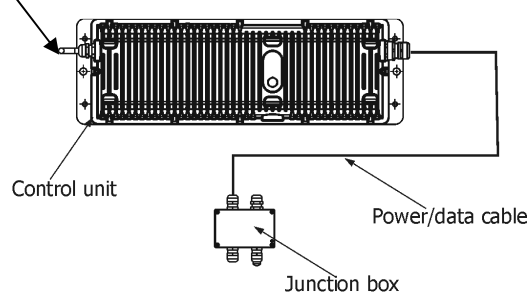

If the LED modules and the base are installed separately on the metal structure (LED modules and the base are galvanic interconnected), the LED modules fall under protection class I and must be grounded in accordance with all national and local electrical and construction regulations.

In case that LED modules and the base are installed separately on the insulant e.g. wall (LED modules and the base are not galvanic interconnected), the LED modules fall under protection class 3 and do not need to be grounded.

ArcPad Xtreme

Cables

- LED modules connection: cable: Belden 7930A Cat. 5e; AWG 24
connectors: 4x Buccaneer PX041108S; 4x Buccaneer PX041008P

NOTE: max. length between LED module and control unit: 20m

- Connection between control unit and junction box: Li9YCHY Cable 3xAWG16+1x (2xAWG24 Shielded and Jacketed)

Dimensions (mm)

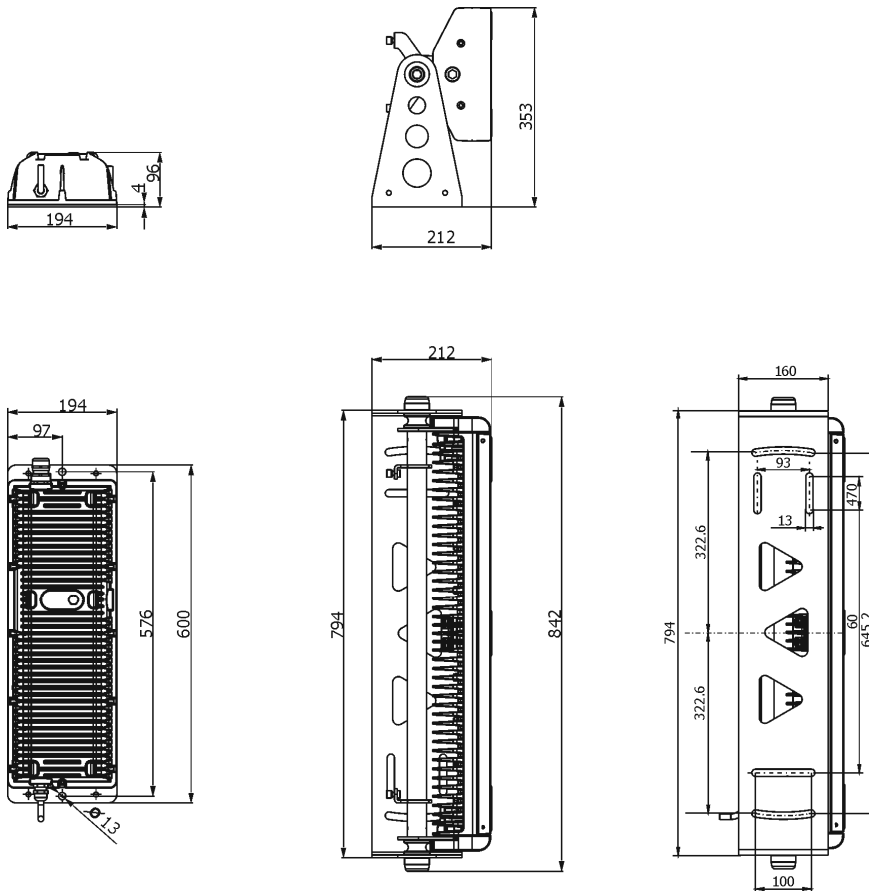

Weight

LED module with mounting bracket: 24 kg

Control unit: 9 kg

Specifications are subject to change without notice.

August 23, 2011

