

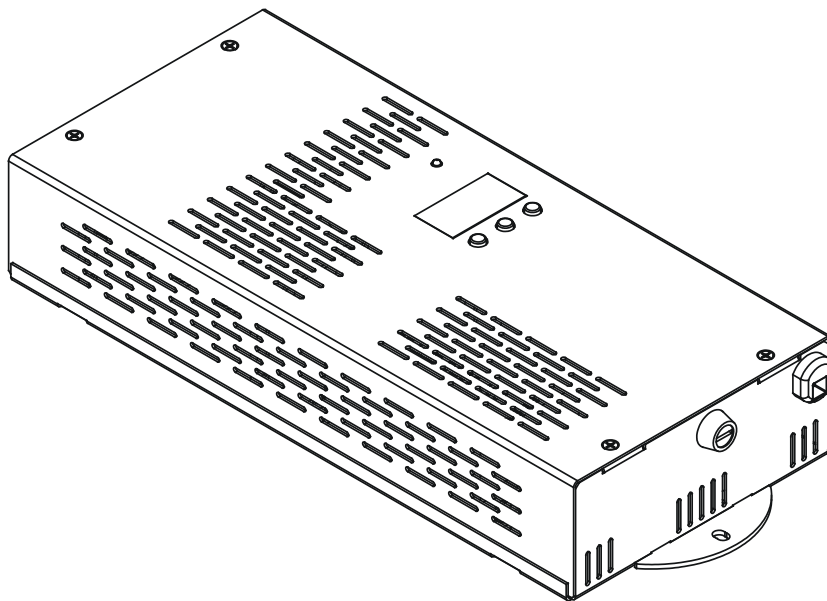

# ArcPower 72



**USER MANUAL**

version 1.7

# ArcPower 72

## Table of contents

<b>1. Safety instructions</b> .....	<b>3</b>
<b>2. Operating determinations</b> .....	<b>3</b>
<b>3. Description of the ArcPower 72</b> .....	<b>4</b>
<b>4. Installation</b> .....	<b>4</b>
4.1. Connection to the mains .....	4
4.2. Mounting the ArcPower 72 .....	5
4.3. Connection cables.....	5
<b>5. Installing instructions.</b> .....	<b>6</b>
5.1. DMX operating .....	6
5.2. Master-slave operating.....	8
5.3. Operating via Dynet protocol.....	9
<b>6. ArcPower 72 - Control menu map</b> .....	<b>11</b>
<b>7. ArcPower 72-DMX protocol</b> .....	<b>12</b>
<b>8. Control board</b> .....	<b>13</b>
8.1 Addressing the ArcPower 72 .....	13
8.2 Program running .....	13
8.3 Manual mode .....	14
8.4 Test sequences.....	15
8.5 Stand-alone mode.....	15
8.6 Special functions .....	15
<b>9. Control of the ArcPower 72 via RS-232</b> .....	<b>17</b>
9.1 Wiring an RS-232 serial port .....	17
9.2 Selecting a zone.....	17
9.3 Setting a serial port of PC .....	17
9.4 Zone commands .....	17
<b>10. Technical Specifications</b> .....	<b>19</b>
<b>11. Replacing the fuse</b> .....	<b>20</b>

**CAUTION!**  
***Unplug mains lead before opening the housing!***

**FOR YOUR OWN SAFETY, PLEASE READ THIS USER MANUAL CAREFULLY  
BEFORE YOU INITIAL START - UP!**

## **1. Safety instructions**

Every person involved with installation and maintenance of this product has to:

- be qualified
- follow the instructions of this manual

**CAUTION!**  
***Be careful with your operations. With a high voltage you can suffer  
a dangerous electric shock when touching the wires inside the unit!***

This product has left our premises in absolutely perfect condition. In order to maintain this condition and to ensure a safe operation, it is absolutely necessary for the user to follow the safety instructions and warning notes written in this manual.

***To prevent from danger of accident ,the device has to be fixed on flat, non-flammable surface in compliance with the installing instruction included in this manual.***

### **Important:**

The manufacturer will not accept liability for any resulting damages caused by the non-observance of this manual or any unauthorized modification to the product.

Always ground the unit.

The electric connection, repairs and servicing must be carried out by a qualified employee.

Do not connect this unit to a dimmer pack.

Use a source of AC power that complies with local building and electrical rules. AC power has to have both overload and short circuit protection

## **2. Operating determinations**

This product was designed for indoor use only.

If the unit has been exposed to drastic temperature fluctuation (e.g. after transportation), do not switch it on immediately. The arising condensation water might damage your unit. Leave the unit switched off until it has reached room temperature.

Avoid brute force when installing or operating the unit.

When choosing the installation-spot, please make sure that the unit is not exposed to extreme heat, moisture or dust.

Only operate the unit after having checked that the housing is firmly closed and all screws are tightly fastened.

The maximum ambient temperature 40° C must never be exceeded.

Operate the unit only after having familiarized with its functions. Do not permit operation by persons not qualified for operating the unit. Most damages are the result of unprofessional operation!

Please use the original packaging if the product is to be transported.

Please consider that unauthorized modifications on the unit are forbidden due to safety reasons!

### 3. Description of the ArcPower 72

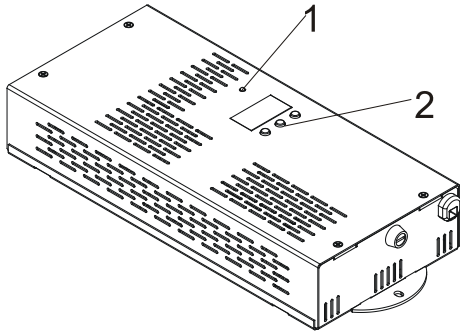

- 1 - Power Indicator
- 2 - Control board
- 3 - DMX Output
- 4 - DMX Input
- 5 - LED Zone 1 output
- 6 - LED Zone 2 output
- 7 - RS 232 Output
- 8 - Fuse Holder
- 9 - Power Cord

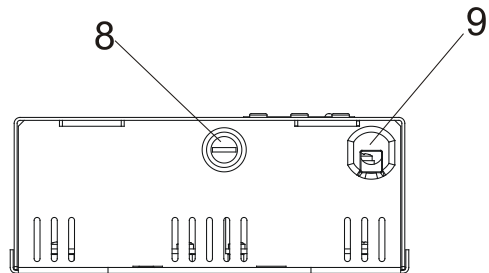
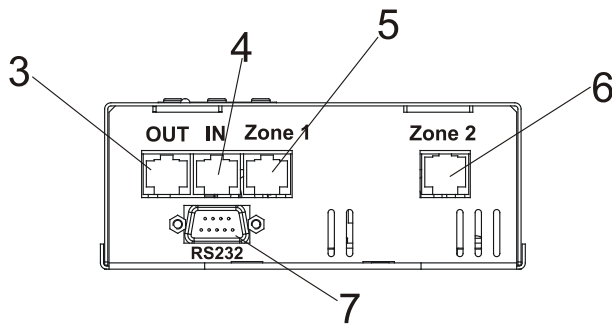

#### DMX Input

- Pin 1: Not connected
- Pin 2: +12V
- Pin 3: Not connected
- Pin 4: Not connected
- Pin 5: Not connected
- Pin 6: Data +
- Pin 7: Data -
- Pin 8: GND

RJ45 socket

Front view of the socket:

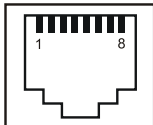

#### DMX Output

- Pin 1: Not connected
- Pin 2: Not connected
- Pin 3: Not connected
- Pin 4: Not connected
- Pin 5: Not connected
- Pin 6: Data +
- Pin 7: Data -
- Pin 8: GND

#### LED module Input

- Pin 1: Red LED +
- Pin 2: Green LED +
- Pin 3: Blue LED +
- Pin 4: White LED +
- Pin 5: Red LED -
- Pin 6: Green LED -
- Pin 7: Blue LED -
- Pin 8: White LED -

#### RS232 Input

9-pin D connector

Front view of the socket:

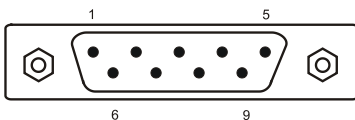

- Pin 1: Not connected
- Pin 2: Received Data
- Pin 3: Transmitted Data
- Pin 4:
- Pin 5: Signal Ground
- Pin 6:
- Pin 7:
- Pin 8:
- Pin 9: Not connected

### 4. Installation

#### 4.1. Connection to the mains

The ArcPower 72 is equipped with auto-switching power supply that automatically adjusts to any 50/60Hz AC power source from 100-240 Volts.

Carefully prepare the end of the the supply cord and fit a suitable plug. A 3-prong grounding-type plug must be

installed following the manufacturer's instructions. The earth has to be connected!

Cord plug connections:

Cable	Pin	International
Brown	Live	L
Light blue	Neutral	N
Yellow/Green	Earth	

**This device falls under protection class I. Therefore the ArcPower 72 has to be connected to a mains socket outlet with a protective earthing connection.**

### 4.2. Mounting the ArcPower 72

The ArcPower 72 should be placed on a non-flammable flat surface in any orientation and fixed by the two screws. There are two mounting holes of diameter 5 mm in housing of the driver. Ensure that installation place is enough ventilated.

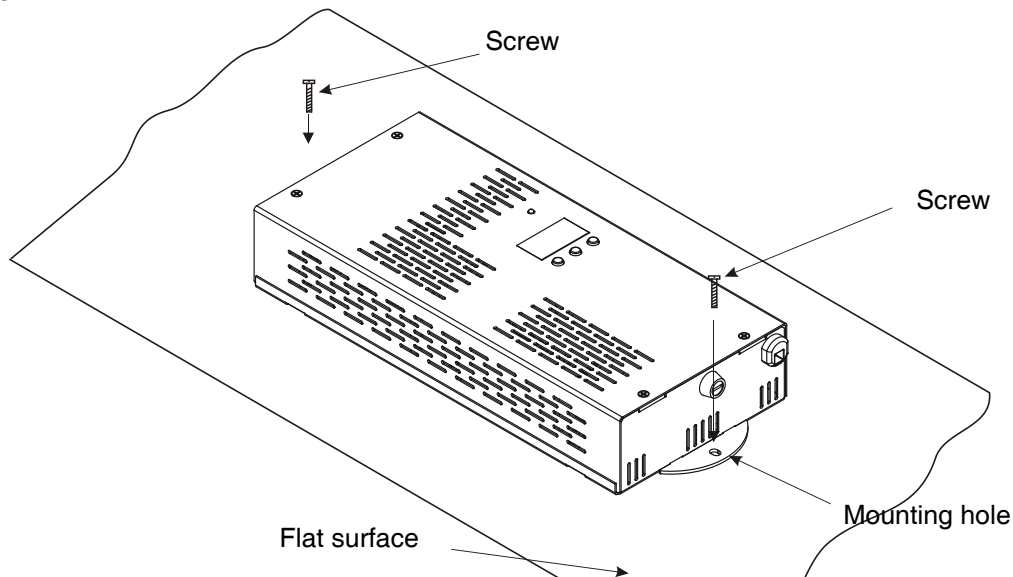

### 4.3. Connection cables

1. The adapter cable RJ45/XLR connects the ArcPower 72 to the DMX controller. If your DMX controller has RJ45 socket for DMX output, use RJ45 patch cable for connection with the ArcPower 72.

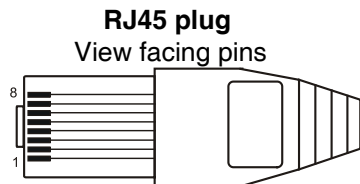
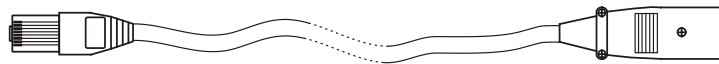

- Pin 1: Not used
- Pin 2: Not used
- Pin 3: Not used
- Pin 4: Not used
- Pin 5: Not used
- Pin 6: Data +
- Pin 7: Data -
- Pin 8: GND

**DMX 512 XLR plug (male)**  
Front view of the plug



- Pin 1: GND
- Pin 2: Data -
- Pin 3: Data +
- Pin 4: Not used
- Pin 5: Not used

2.RJ45 patch cables category 5 that connect the ArcPower 72 each other are wired 1:1,that is,pins with the same numbers are connected together.



<b>Pin 1:</b> Not used	<b>Pin 1:</b> Not used
<b>Pin 2:</b> Not used	<b>Pin 2:</b> Not used
<b>Pin 3:</b> Not used	<b>Pin 3:</b> Not used
<b>Pin 4:</b> Not used	<b>Pin 4:</b> Not used
<b>Pin 5:</b> Not used	<b>Pin 5:</b> Not used
<b>Pin 6:</b> Data +	<b>Pin 6:</b> Data +
<b>Pin 7:</b> Data -	<b>Pin 7:</b> Data -
<b>Pin 8:</b> GND	<b>Pin 8:</b> GND

## 5.Installing instructions.

### 5.1.DMX operating

- 1.Unplug from the mains before installation.
- 2.Connect the LED modules to the fixture.
- 3.Connect the DMX controller to the fixture
- 4.Connect the fixture to the mains
- 5.Set the DMX address on the control board of the fixture (see chapter "Control board").

**Warning!**  
**Accidental connection DMX 512 Input/Output to non-DMX 512 device (e.g.Ethernet network Hub) can damage the ArcPower 72.**  
**Maximum total cable length between one LED zone output of the Arcpower 72 and all its connected LED modules is 80 metres.**

#### Single ArcPower 72 installation:

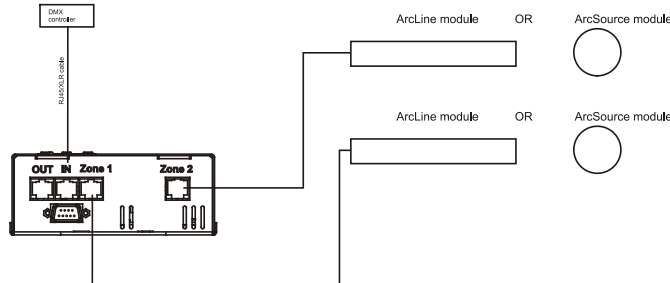

#### Multiple ArcPower 72 installation:

Connect the DMX output of the first ArcPower 72 with the DMX input of the next ArcPower 72. Always connect one output with the input of the next ArcPower 72 until all fixtures are connected.In this way,up to 32 fixtures can be chained together.

At the last ArcPower 72 the data link has to be terminated with a terminator. A termination plug is simply a RJ45 connector with a 120 Ω resistor between pins Data (-) and Data (+).Plug terminator in the DMX output of the last ArcPower 72.

Maximum number of LEDs connected to the one zone of the ArcPower 72 is 36 in RGB mode and 42 in RGBW mode.

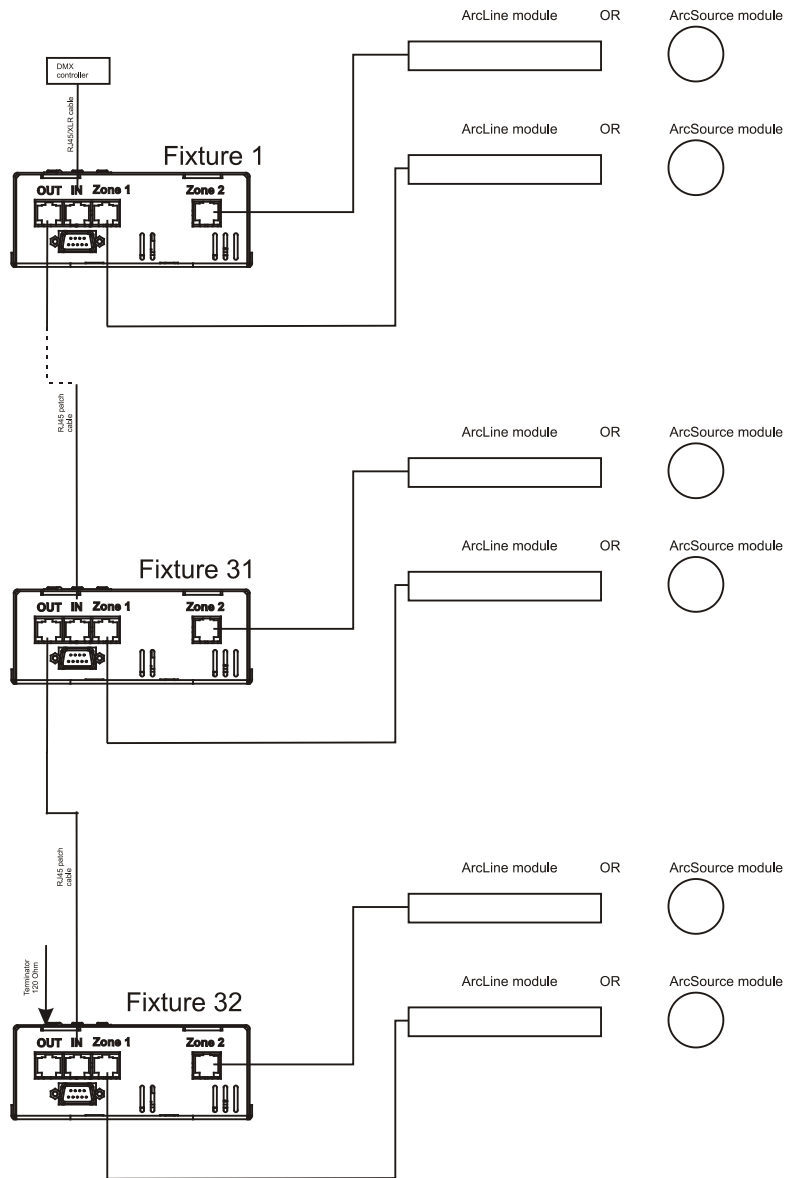

Maximum possible number of LED modules connected to the one zone of the ArcPower 72:

Model	total LEDs	Red LEDs	Green LEDs	Blue LEDs	White LEDs	Max.number of connected modules
ArcLine 12 RGB	12	4	4	4	-	3
ArcLine 24 RGB	24	8	8	8	-	1
ArcLine 36 RGB	36	12	12	12	-	1
ArcLine Optic 12 RGB	12	4	4	4	-	3
ArcLine Optic 24 RGB	24	8	8	8	-	1
ArcLine Optic 36 RGB	36	12	12	12	-	1
ArcSource 3 RGB	3	1	1	1	-	12
ArcSource 6 RGB	6	2	2	2	-	6
ArcSource 12 RGB	12	4	4	4	-	3
ArcSource 7 RGBW	7	2	2	2	1	6

**Note: You cannot combine RGB and RGBW modules (e.g. ArcSource 6 RGB and ArcSource 7 RGBW) each other as white LEDs will not light.**

## 5.2. Master-slave operating

1. Unplug from the mains before installation.
2. Connect the LED modules to the fixtures.
3. Connect the DMX output of the master fixture in the data-chain with the DMX input of the first slave. Always connect output with the input of the next slave until all slaves are connected. Up to 32 fixtures can be connected in master/slave chain
4. Insert the termination plug (with 120 Ohm) into DMX input of the master fixture and into the DMX output of the last slave fixture in the link in order to ensure proper transmission on the data link.
5. Connect the fixtures to the mains.
6. See chapter "Stand-alone mode" in order to set the fixture as a master or slave.

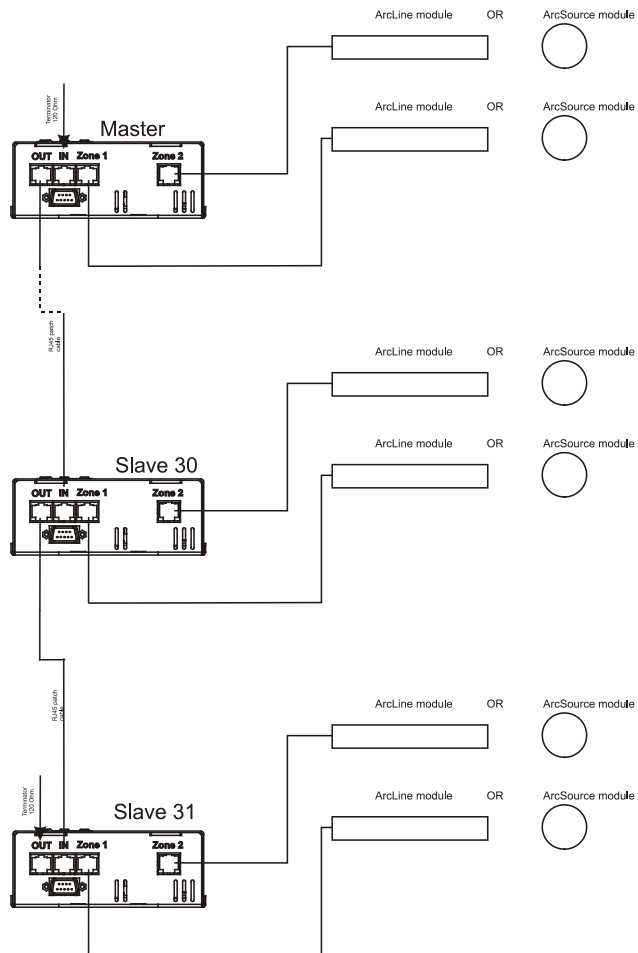

### 5.3. Operating via DyNet protocol

1. Unplug from the mains before installation.
  2. Connect LED modules to the fixtures.
- Connect first fixture to the control panel which supports DyNet protocol (e.g. DLP 8100)
3. Connect the DMX output of the first fixture in a data link with the DMX input of the second fixture. Always connect output with the input of the next fixture until all fixtures are connected. Up to 32 fixtures can be connected in data chain.
  4. Insert the termination plug (with 120 Ohm) into DMX output of the last fixture in order to ensure proper transmission on the data link.
  5. Connect fixtures to the mains
  6. Select the DyNet protocol on all fixtures (menu SPE"---> Prt---> "dYn").

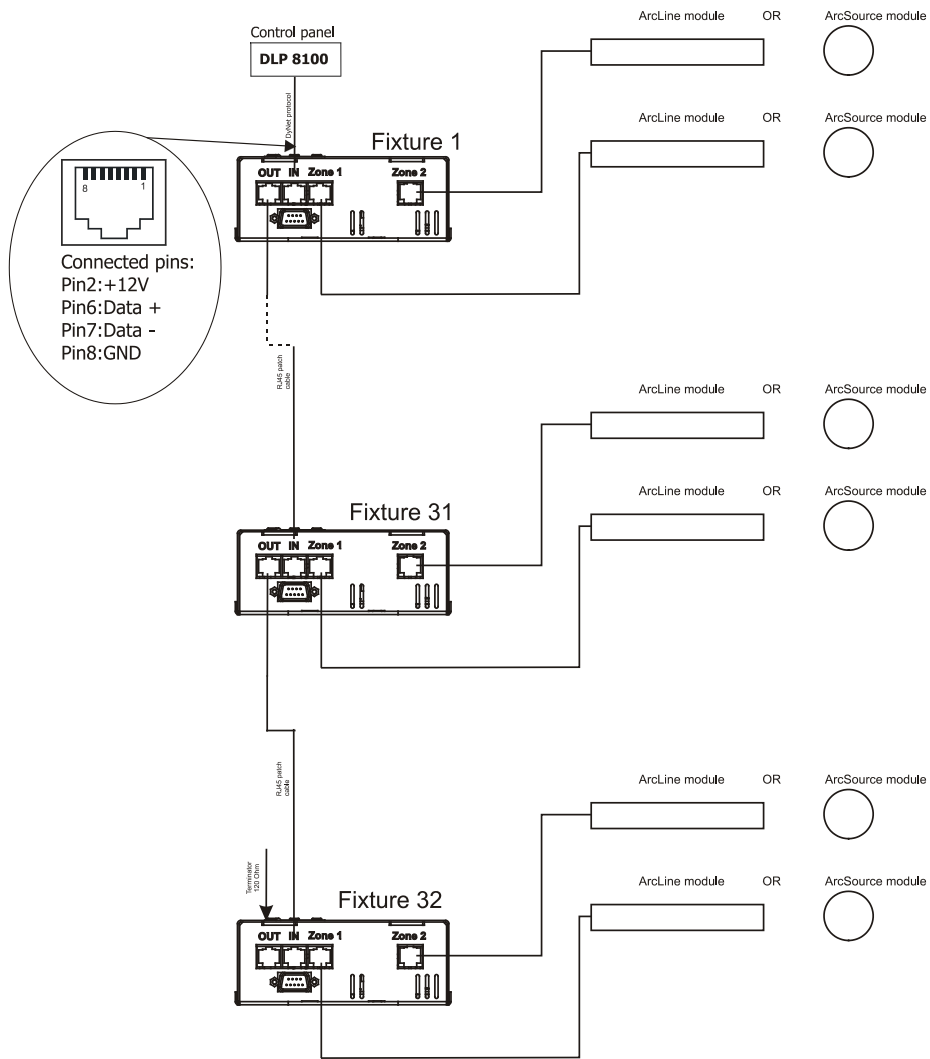

A description of each byte in DyNet protocol is the following:

Byte 0: 1C - hexadecimal Logical Message (fixed value)  
Byte 1: 01 - Area  
Byte 2: 00 - Channel level  
Byte 3: 80 - Channel  
Byte 4: ff - Channel Offset  
Byte 5: 00 - Fade Rate  
Byte 6: FF (fixed value)  
Byte 7: 1C Checksum

**Area** - (0 to 255), as set on the Arcpower to give a unique address for each Arcpower unit (i.e. DMX base address)

**Channel Level** - (0 to 255), level - 01=100%, FF=0%

**Channel** - (80 to 83), 80= channel 1, 81= channel 2, 82= channel 3, 83= channel 4, (see Channel Offset if more than 4 channels)

**Channel Offset** - (0-255), default (FF)- channel offset in blocks of 4: (FF = CH 1-4, 00 = CH 5-8, 01 = CH 9-12, etc up to 3E = CH 253-256 )

**Fade Rate** - (0-255), fade rate with 1 second resolution (0= 0 seconds, 255= 255 seconds)

**Checksum** - (0-255), checksum Byte - used to ensure the integrity of the packet.  
Negative two's compliment of the preceding 7 bytes.

Example 1:

0x1C,0x10,0x00,0x80,0xff,0x05,0xff,0x52

This would control channel 1 (i.e. Red) of Arcpower unit, address 16 to a Level of 100% with a fade of 5 seconds.

Example 2:

0x1C,0x05,0xCC,0x82,0xff,0x0A,0xff,0x52

This would control channel 3 (i.e. Blue) of Arcpower unit, address 5 to a level of 20% with a fade of 10 seconds.

## 6.ArcPower 72 - Control menu map

Default settings=**Bold print**

**001** (001-502)

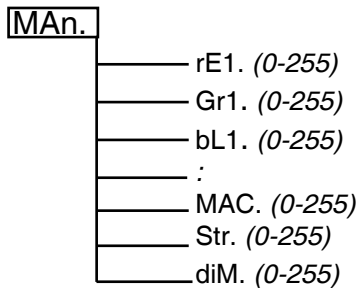
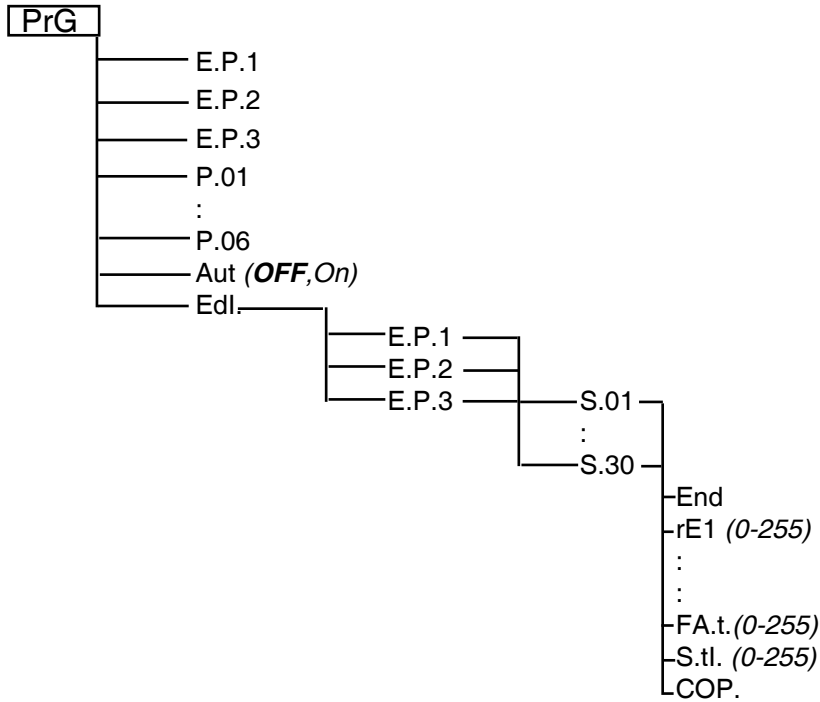

**tSt**

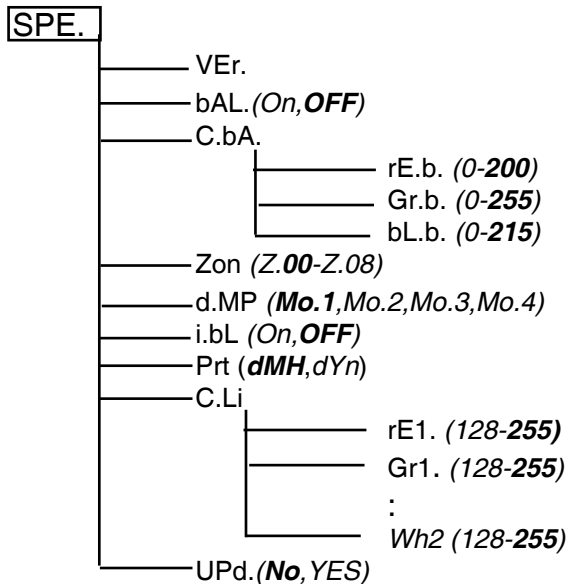
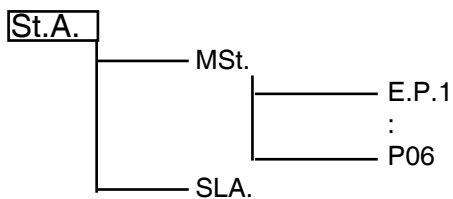



## 8. Control board

The control panel situated on the top cover of the ArcPower 72 allows DMX addressing, calling Built-in programs and setting the fixture behaviour

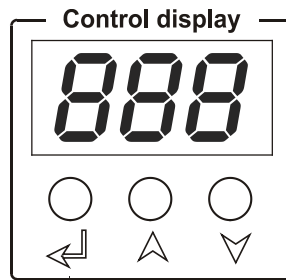

### Control elements:

- ↵ [ENTER] button- enters menu, confirms adjusted values and leaves menu.
- ↑, ↓ [UP] button and [DOWN] button- moves between menu items on the the same level, sets values. In order to leave the menu without saving value, press [UP] and [DOWN ] at the same time.

After switching on the ArcPower 72 ,the display shows the initial DMX address:



Use [UP],[DOWN] to browse through the menu. To select a function or submenu,press [ENTER].

### 8.1 Addressing the ArcPower 72



The fixture can be operated in the two modes:**DMX mode**-fixture is controlled via DMX 512 by an external DMX controller

**Stand-alone mode** - fixture uses Built-in programs and is able to control other fixtures in the master/slave chain.

See the chapter "Stand-alone mode" for detail description.

For DMX mode, it is important to define the starting DMX address from which the ArcPower 72 will respond to the DMX controller

#### Setting the DMX start channel for DMX operating:

1. Connect ArcPower 72 to the mains.
2. Browse through the menu by pressing the [UP] and [DOWN] buttons until the display shows current address "001". Confirm by pressing [ENTER] button and "001" will start to flash frequently.
3. Use the [UP] and [Down] buttons to select the desired address.
4. Confirm by pressing [ENTER].

After having addressed ArcPower 72, you may now start operating ArcPower 72 via your DMX controller.

### 8.2 Program running



By entering this menu a complete overview of all programs is offered, from which the program to be run can be selected by pressing [ENTER]. Selected program runs in a loop. The fixture includes 6 built-in programs (P.01-P.6) and 3 free editable programs (E.P.1-E.P.3), each up to 30 steps.

If item "Aut" is On, the fixture in DMX mode will remember last running program and this program will run after switching on the fixture.

Each program step has a fade time - the time during which effects go to the current step and a Standing time - the time, during which effects last in the current step.

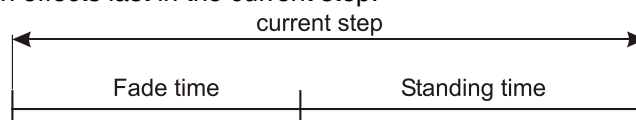

Programming procedure:

1. Enter "Edl." menu
  2. Press [UP] or [DOWN] to select the desired program which you wish to edit and press [ENTER].
  3. Press [UP] or [DOWN] to select the desired program step ("S.01" - "S.30") and press [ENTER].
  4. Press [UP] or [DOWN] to select the desired item and press [ENTER]-button. Now you can edit by using [UP] or [DOWN] buttons the DMX values selected item (the list of items depends on selected DMX mode):
- End.** - a total number of the program steps (value 1-30). This value you must set before start programming (e.g. if you want to create program with 10 steps, set End=10).

- |  |  |
|--|--|
| <b>rE1</b> - a red LED 1 saturation, value 0-255   | <b>rE2</b> - a red LED 2 saturation, value 0-255   |
| <b>Gr1</b> - a green LED 1 saturation, value 0-255 | <b>Gr2</b> - a green LED 2 saturation, value 0-255 |
| <b>bL1</b> - a blue LED 1 saturation, value 0-255  | <b>bL2</b> - a blue LED 2 saturation, value 0-255  |
| <b>Wh1</b> - a white LED 1 saturation, value 0-255 | <b>Wh2</b> - a white LED 2 saturation, value 0-255 |

**Following item are common for all zones:**

- MAC.** - a macro selection, value 0-255
- Str.** - a strobe, value 0-255
- dim.** - a dimmer, value 0-255
- FA.t.** - fade time, value 0-255\*
- S.tl.** - standing time, value 0-255\*
- COP.** - copying the current prog. step to the next prog. step.  
Press [ENTER]-button to confirm adjusted value.

5. Repeat steps 3 and 4 for next prog. step. If you want to copy current program step to the next prog. step, select option „COP.“ and confirm it by pressing [ENTER].

\*Both Fade time and Standing time use the same conversion table in order to convert DMX value to the time value:

DMX	Time [sec.]	DMX	Time [min.]	DMX	Time [min.]	DMX	Time [min.]	DMX	Time [min.]
1	0.1	50	4.2	105	18.4	160	42.7	215	77
2	0.4	55	5	110	20.2	165	45.4	220	80.7
5	2.5	60	6	115	22	170	48.2	225	84.4
10	10	65	7	120	24	175	51	230	88.2
15	22.5	70	8.2	125	26	180	54	235	92
20	40	75	9.4	130	28.2	185	57	240	96
25	62.5	80	10.7	135	30.4	190	60.2	245	100
30	90	85	12	140	32.7	195	63.4	250	104
35	122.5	90	13.5	145	35	200	66.7	255	108
40	160	95	15	150	37.5	205	70		
45	202.5	100	16.7	155	40	210	73.5		

Exact expression of the time value follows the formula: time[sec.]=(DMX value)<sup>2</sup>/10.

### 8.3 Manual mode



This menu gives access to the control of the fixture channels by means of the control buttons.

Use [UP] and [DOWN] buttons until the display shows "MAN." menu. Press [ENTER] button and by using [UP] and [DOWN] buttons select desired effect, press [ENTER] and and by using [UP] and [DOWN] buttons adjust desired DMX value for selected effect. Confirm by [ENTER].

- |  |  |
|--|--|
| <b>rE1</b> - a red LED 1 saturation, value 0-255   | <b>rE2</b> - a red LED 2 saturation, value 0-255   |
| <b>Gr1</b> - a green LED 1 saturation, value 0-255 | <b>Gr2</b> - a green LED 2 saturation, value 0-255 |
| <b>bL1</b> - a blue LED 1 saturation, value 0-255  | <b>bL2</b> - a blue LED 2 saturation, value 0-255  |
| <b>Wh1</b> - a white LED 1 saturation, value 0-255 | <b>Wh2</b> - a white LED 2 saturation, value 0-255 |

**MAC.** - a macro selection, value 0-255

**Str.** - a strobe, value 0-255

**dim.** - a dimmer, value 0-255

The list of items depends on the DMX mode that has been chosen,.

## 8.4 Test sequences



Use the item to run a special demo-test sequences without an external controller, which will show you some possibilities of using the fixture.

## 8.5 Stand-alone mode



Select this menu to set fixture behaviour in stand-alone mode without an external controller.

Synchronous operation of multiple fixtures requires that they must be connected on a data link and one of them is set as a master ("MSt") and the rest as the slaves ("SLA"). Only one fixture can be set as the master. The slaves mimic the behavior of the master. Effect actions are triggered by an internal timer of the master fixture.

**Important!:** Disconnect the fixtures from the DMX controller before master/slave operating, otherwise data collisions can occur and the fixtures will not work properly!

**MSt.** --- **Master.** Enter this menu if you want to set the the fixture as a master. Use [UP] and [DOWN] buttons to select desired program and press [ENTER] to confirm selection.

**SLA.** --- **Slave.** Enter this menu if you want to set the the fixture as a slave.

The master fixture starts simultaneous program start in the other slave fixtures. All fixtures are synchronized in every prog.steps. The fixtures run their programs repeatedly (e.g. if master runs its program "P05", all slaves will be executed program also "P05").

**Note:** If the master runs its editable program (EP1, EP2 or EP3), all slaves will execute their own editable programs (EP1, EP2 or EP3) according the master, but both fade time (FA.t.) and standing time (S.tl.) for each step will be taken from the master's step (slaves' times are eliminated in each step).

## 8.6 Special functions



Use this menu for special services.

**VER.** --- **Software Version.** Select this function to read the number of the fixture software.

**bAL.** --- **Balance.** Select this function to enable (On) or disable (OFF) the white balance which is set in "White colour balance" menu below. If this function is set OFF, ArcPower 72 will use maximum value (255) of saturation for red, green and blue channel.

**C.bA.** --- **White colour balance.** Using this menu you can set white balance:

1. Browse through the menu by pressing the [UP] and [DOWN] buttons until the display shows "C.bA." menu. Press [ENTER] button and "rE.b." will appear on the display.
2. Press [ENTER] button again and use [UP] and [DOWN] buttons to adjust the new maximum value required for the red channel. Confirm your choice by pressing [ENTER]. Use the [UP] and [Down] buttons to select next colour.
3. Repeat step 2 for green channel "Gr.b." and for blue channel "bL.b."

**Zon.** --- **Zone selecting.** **Zon.** The option enables select desired number of the zone (from 0 to 8).

The number of the zone distinguishes individual zones of the ArcPower 72 which is controlled via RS-232 interface.

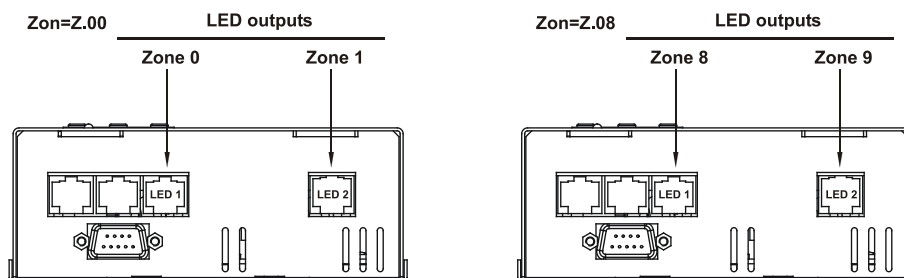

Use [UP] and [DOWN] buttons to select desired zone and press [ENTER] to confirm selection. The selected zone number is assigned to the first LED output and the second one has its zone number by one number higher.

**d.MP. --- DMX presetting.** The function makes possible to select from 3 DMX modes. Use [UP] and [DOWN] buttons to select desired channel mode ("Mo.1-4") and press [ENTER] to confirm selection.

**i.bL. --- Initial blink.** If this function is on, ArcPower 72 makes auto-calibration (All LEDs light on 100% for short time) after switching it on. If this function is set off, you have to set manually every colour on max. brightness after switching on the driver before starting regular operating. This action should last min. one second. In this moment, the ArcPower 72 finds out the load connected to its LED output and makes auto-calibration.

**Prt --- Protocol selection** - Selects a required communication protocol.

dMH - the fixture will communicate using DMX 512 signal.

dYn - the fixture will communicate using the DyNet protocol.

**C.Li. --- Current limiting.** The menu item allows to reduce a current-carrying capacity of each LED branch (colour) in order to keep a declared lifetime of LED modules. The situation can occur if you operate LED modules at an higher ambient temperature than is recommended (40°C).

The current-carrying capacity can be changed in a range of 350 - 175 mA (255-128) linearly. A default value is 255 (350 mA).

To adjust the current limiting:

1. Browse through the menu by pressing the [UP] and [DOWN] buttons until the display shows "C.Li." menu. Press [ENTER] button and "rE1" item will appear on the display.
2. Press [ENTER] button again and use [UP] and [DOWN] buttons to select desired value. Confirm this value by pressing [ENTER]. Use the [UP] and [Down] buttons to select next colour.
3. Repeat step 2 for items "Gr1", "bL1", "Wh1", "rE2", "Gr2", "bL2" and "Wh2".

**UPd. --- Software update** - Using this function you can update software in the fixture via PC and serial link.

The following are required in order to update software:

- PC running Windows 95/98/2000/XP or Linux
- DMX Software Uploader
- Flash cable RS232/DMX (No.13050624)

**Note1:** Software update should execute a qualified person. If you lack qualification, do not attempt the update yourself and ask for help your ANOLIS distributor.

**Note 2:** DMX address, programs and all settings will be set to their default values.

**To update software in the fixture:**

1. Installation of DMX Software Uploader:

1. DMX Software Uploader program is available from the ANOLIS web site at [WWW.anolis.cz](http://WWW.anolis.cz).
2. Make a new directory ( e.g. ANOLIS\_Uploader) on your hard disk and download the software to it.
3. Unpack the program from the archives. Program file has name: DSU\_name of corresponding fixture\_SoftwareID. SoftwareID describes the versions of fixture software included in DMX Software Uploader. Higher number means later software versions.

2. Fixture software updating:

1. Determine which of your COM port is available on your PC and connect it with to the DMX input of the fixture using the Flash cable. Do not extend this cable! Disconnect the fixture from the other fixtures in DMX chain! Turn on the computer and the fixture.
2. Switch the fixture to the update mode by selecting the option Software update in menu Special Functions on the fixture control panel: SPE-->UPd-->yES. (From this option you cannot return back to the main menu. If you do not want to continue in software update, you have to switch off and on the fixture to leave this option!)
3. It is recommended that you exit all programs before running the Software Uploader.
4. Start the Software Uploader program. Select desired COM and then click Connect button. If the connection is OK, click Start Uploading button to start uploading. It will take several minutes to perform software update. All processors will be updated (including processors with the same software version).  
If you wish to update only later versions of processors, enable the Incremental Update check box. Avoid interrupting the process. Update status is being displayed in the list window. When the update is finished, the line with the text "The fixture is successfully updated" will appear in this window and the fixture will reset with the new software.

Note: In the case of interruption of the upload process (e.g. power cut), the fixture remains in the update mode and you have to repeat the software update again.

For example: The fixture was switched off before finishing software upload. After switching the fixture on again, the fixture is still in the update mode and the display is dark. Restart the Software Uploader program and repeat software update from your PC.

## 9. Control of the ArcPower 72 via RS-232

### 9.1 Wiring an RS-232 serial port

9-pin D connector (male)  
Front view of the socket:

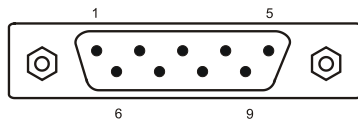

- Pin 1: Not connected
- Pin 2: Received Data
- Pin 3: Transmitted Data
- Pin 4:
- Pin 5: Signal Ground
- Pin 6:
- Pin 7:
- Pin 8:
- Pin 9: Not connected

#### RS-232 cable:

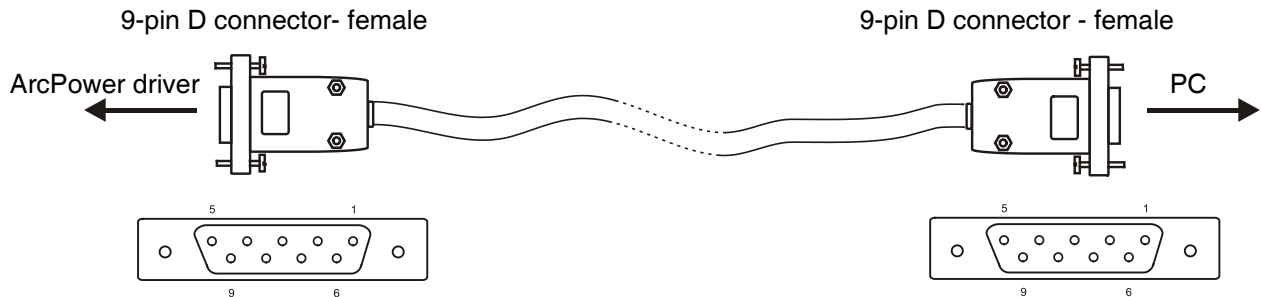

- |                         |       |                         |
|-------------------------|-------|-------------------------|
| Pin 1:                  |       | Pin 1:                  |
| Pin 2: Received Data    | ————— | Pin 2: Received Data    |
| Pin 3: Transmitted data | ————— | Pin 3: Transmitted data |
| Pin 4:                  |       | Pin 4:                  |
| Pin 5: Signal ground    | ————— | Pin 5: Signal ground    |
| Pin 6:                  |       | Pin 6:                  |
| Pin 7:                  |       | Pin 7:                  |
| Pin 8:                  |       | Pin 8:                  |
| Pin 9:                  |       | Pin 9:                  |

The maximum cable length according to the standard is 15 metres or the cable length equals to a capacitance of 2500 pF.

### 9.2 Selecting a zone

The number of the zone distinguishes individual drivers which are controlled via RS-232 interface. Select **SPE** in main menu of the ArPower 72, press [ENTER], use [UP] and [DOWN] buttons to select **Zon**. The option enables to select desired number of the zone (from 0 to 8). Press [ENTER], use [UP] and [DOWN] buttons to select zone number and press [ENTER] to confirm selection.

### 9.3 Setting a serial port of PC

The serial port of your personal computer should be configured as follows:  
9600 Baud, 8 Data Bits, Non Parity, One Stop Bit, No Flow Control Required.

### 9.4 Zone commands

The ArcPower 72 uses the 3 types of the zone commands which can be used in a suitable software running on PC.

All zone commands stated below have to be send to the ArcPower 72 in ASCII codes.

#### Type 1: Selection of the preset colours

The syntax of the command is:

- zone Z red;**
- zone Z green;**

**zone Z blue;**  
**zone Z white;**  
**zone Z yellow;**  
**zone Z cyan;**  
**zone Z magenta;**  
**zone Z blackout;**

**Z** .....means number of the zone (0-9)  
**red/green/blue/white/yellow/cyan/magenta**....determines colour  
**blackout**.....closes light output  
;**.....**means end of character sequence

Examples: zone 3 green;  
          zone 0 blackout;

### **Type 2: Colour mixing-RGB**

The syntax of the command is:

**zone Z r,g,b;**

**Z**..... means number of zone (0-9)  
**r** .....means DMX value of the red colour(0-255)  
**g** .....means DMX value of the green colour (0-255)  
**b** .....means DMX value of the blue colour (0-255)  
;**.....**means end of character sequence  
, .....values of colours have to be separated by a comma.

Examples: zone 0 234,126,165;  
          zone 1 5,18,28;

### **Type 3: Colour mixing-RGBW**

The syntax of the command is:

**zone Z r,g,b,w;**

**Z**..... means number of zone (0-9)  
**r** .....means DMX value of the red colour(0-255)  
**g** .....means DMX value of the green colour (0-255)  
**b** .....means DMX value of the blue colour (0-255)  
**w** .....means DMX value of the white colour (0-255)  
;**.....**means end of character sequence  
, .....values of colours have to be separated by a comma.

Examples: zone 0 156,145,171,211;  
          zone 1 5,18,28,148;

# 10. Technical Specifications

## Power supply:

Input Voltage: 100-240 V AC, 50/60 Hz

Fuse: T 2 A

Max. Power Consumption: 120VA

## Input:

Control: DMX 512 or DyNet protocol

DMX connection: RJ45

RS 232 connection: 9-pin D connector

## Output:

Max. Output Voltage: 48V DC

Max. Output current: 350mA per colour

Max. load per zone : 36 LED's in RGB mode, 42 LED's in RGBW mode

Total load : 72 LED's in RGB mode

84 LED's in RGBW mode

## Maximum total cable length between one LED zone output and all its connected LED modules:

80 metres at max. load .

## DMX channels:

Mode 1: 6 channels

Mode 2: 8 channels

Mode 3: 11 channels

Mode 4: 4 channels

## Control and programming:

Protocol: USITT DMX-512

Two DMX protocol modes for RGB light sources

Two DMX protocol modes for RGBW light sources

Control options: DMX, Auto-trigger

Operation modes: Master/Slave, Stand alone

Programs: 6 Built-in programs + 3 user editable programs up to 30 steps each

Display: 3 digit LED

White colour balance adjusting

Manual control of all DMX channels with LED control panel

## Operating temperature:

-10°C/+40°C

## Dimensions(mm):

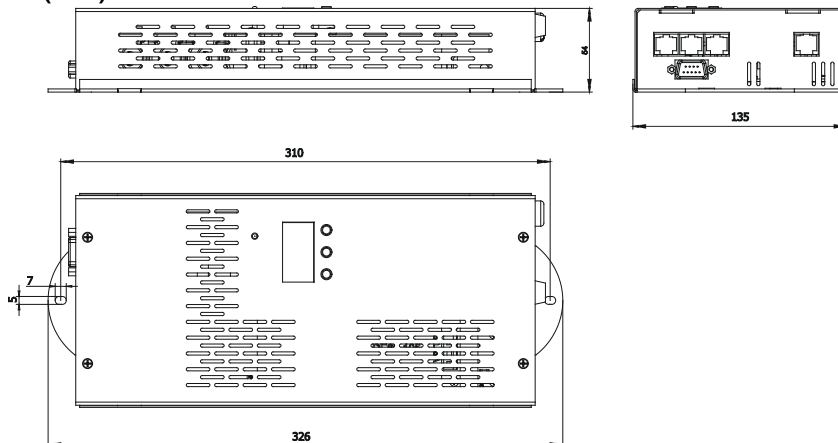

## Weight:

1.8kg

## Accessories:

Cable joiner (No.13050691).....2 pcs

**Optional accessories:**

Adaptor RJ45/DMX 3 pin.....No.13050730

Adaptor RJ45/DMX 5 pin.....No.13050731

## 11. Replacing the fuse

**1.Before replacing the fuse, unplug mains lead!**

**2.**Unscrew the fuse holder on the rear side of the ArcPower 72 with a fitting screwdriver from the housing (anti-clockwise).

**3.**Remove the old fuse from the fuse holder.

**4.**Install the new fuse in the fuse holder.

**5.**Replace the fuse holder in the housing and fix it.